



# Sliplining of Lock-Bar Water Mains, Wilmington Delaware

Andrew Jakubowitch, PE  
January 16, 2014

# Who is Hatch Mott MacDonald? →

- An award-winning, full-service North American engineering consulting firm
- 2,500 employees based in 70 locations, we serve both public and private clients
- Employee-owned
- Projects in more than 150 countries
- More than 11,000 professionals worldwide
- Engineering and project construction management
- Consulting – process, technology and business
- In-house engineering services for operations
- Serving mining & metals, energy and infrastructure clients for 50 years



# City of Wilmington, DE Water Distribution System



- Includes 400+ miles of water mains
  - 13 miles of water mains greater than 36 inches
- Existing system dates back to 1840's
- 37,000 customers
- Water Sources: Brandywine Creek and Hoopes Reservoir
- Large mains used for transmission of raw and treated water
  - Ductile iron pipe
  - Reinforced concrete pipe
  - Lock bar steel pipe
  - Cast iron pipe



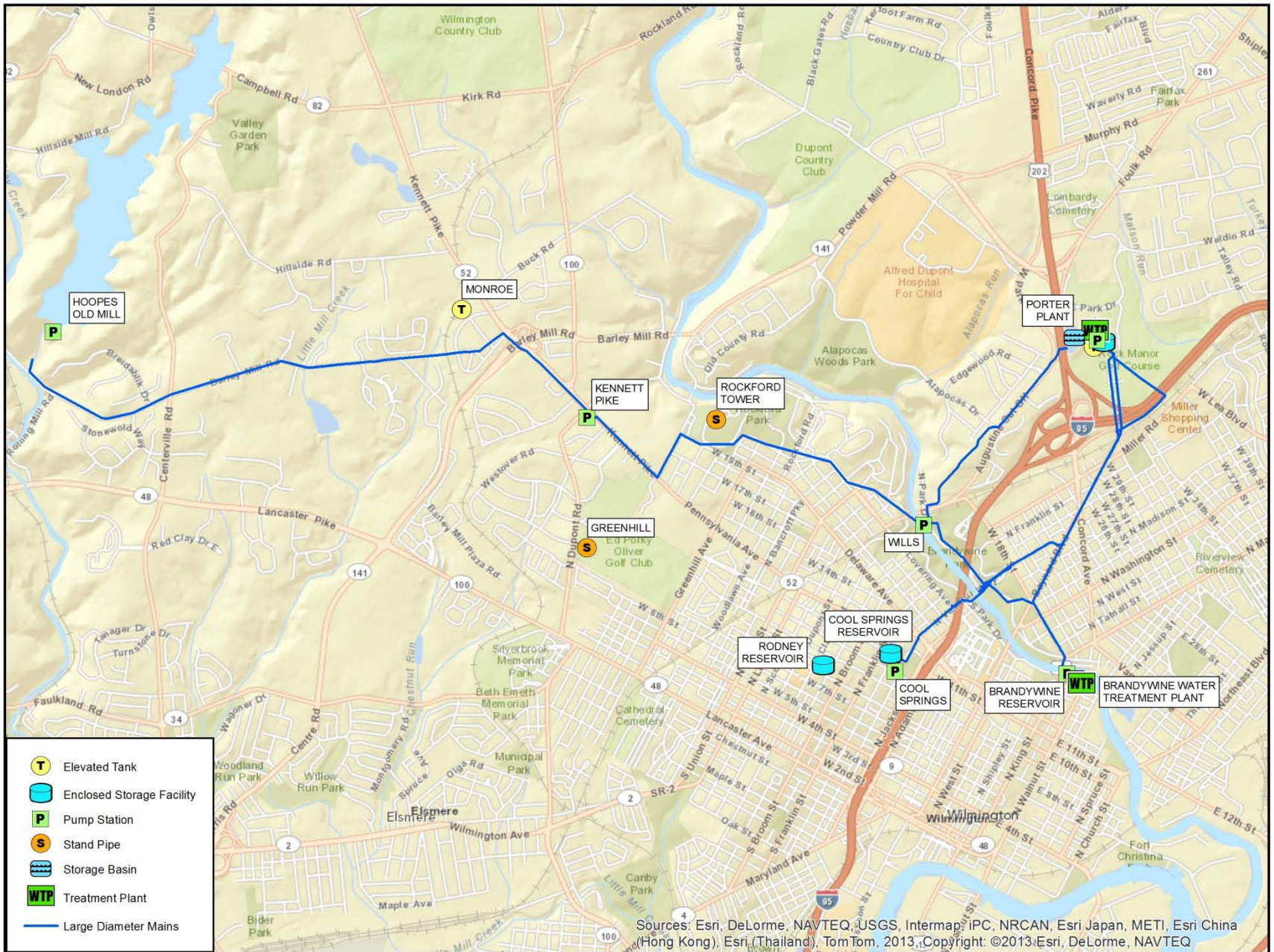

Sources: Esri, DeLorme, NAVTEQ, USGS, Intermap, IPC, NRCAN, Esri Japan, METI, Esri China (Hong Kong), Esri (Thailand), TomTom, 2013, Copyright: ©2013 Esri, DeLorme, NAVTEQ

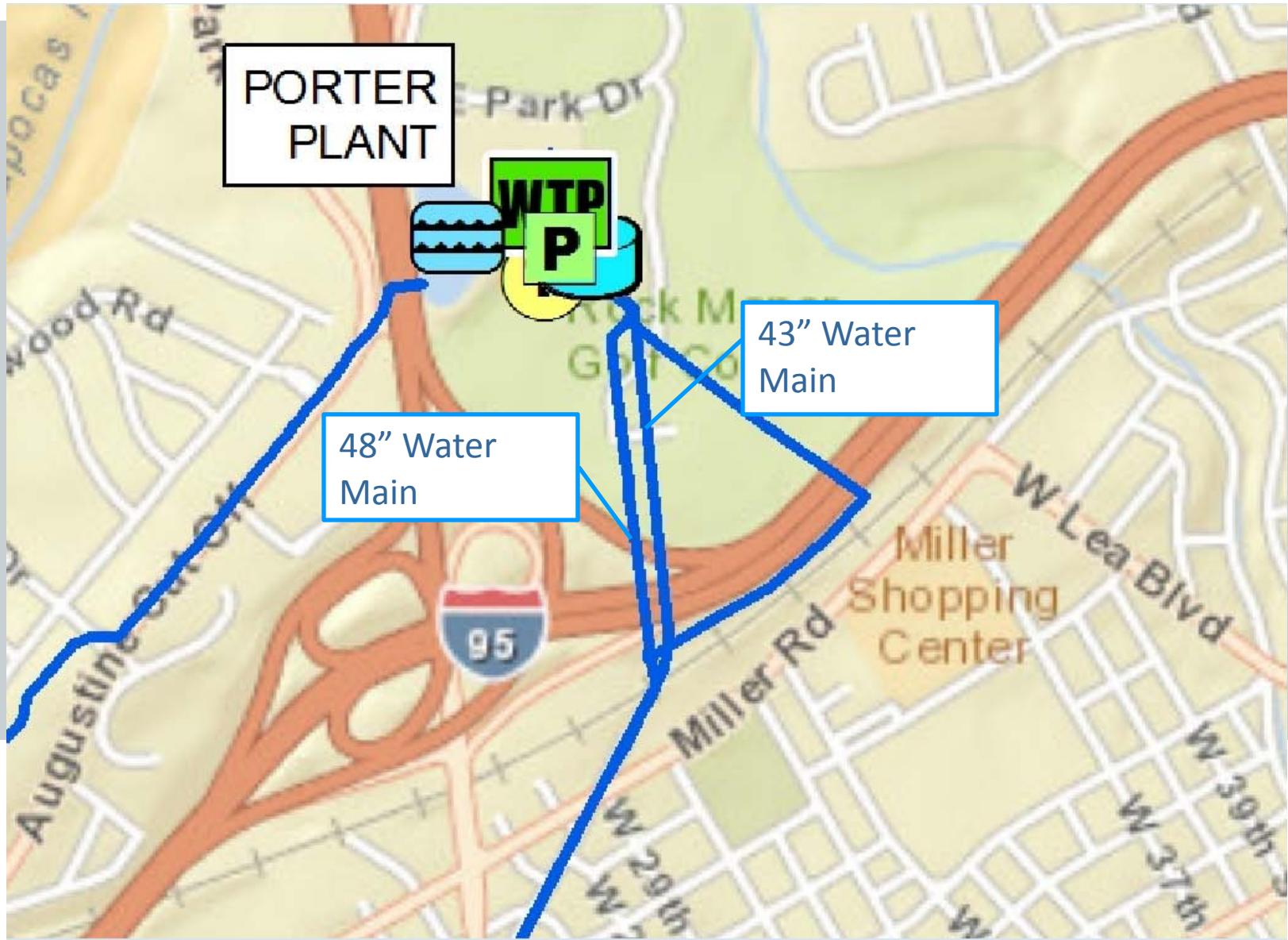



Hatch Mott  
MacDonald

# 43-inch and 48-inch Lock-bar Steel Pipe



- 2 water mains located under I-95
  - 43" lock bar steel, raw water main
  - 48" lock bar steel, treated water main
  - Installed 1901 – before the I-95 existed
- Existing mains protected by steel archway during original construction of highway





Hatch Mott  
MacDonald

# Lock-bar Pipe With Arches →





Hatch Mott  
MacDonald

# Lock-bar Steel Pipe →







**Lock-bar Steel Pipe** is made by upsetting the edges of the plates and connecting them by a lock bar in the shape of an H going over the opposite edges and being forced down over them by hydraulic pressure. This takes the place of the riveting in the longitudinal joints. The circular joints may be made by riveting or otherwise as for riveted pipe. While double riveting develops only about 72 % of the strength of the steel plate, the lock bar is capable of developing 100%.

Owing to occasional defects in material or workmanship on the lock bars, in making calculations it is recommended that only 90 % of the strength of the plate should be used for lock-bar pipe. Two sheets of steel each 30 ft long are

joined with two bars at their edges to make a 30-foot length of pipe. The circular joints between these lengths are usually riveted in the field. Thus far lock-bar pipe has been made from plates ranging from  $\frac{1}{4}$  to  $\frac{7}{16}$  inch in thickness.

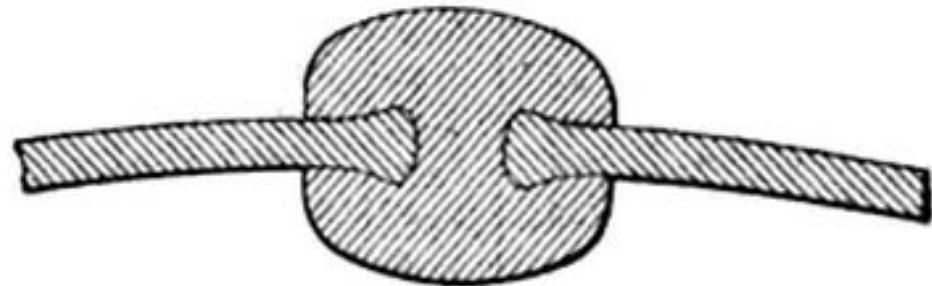
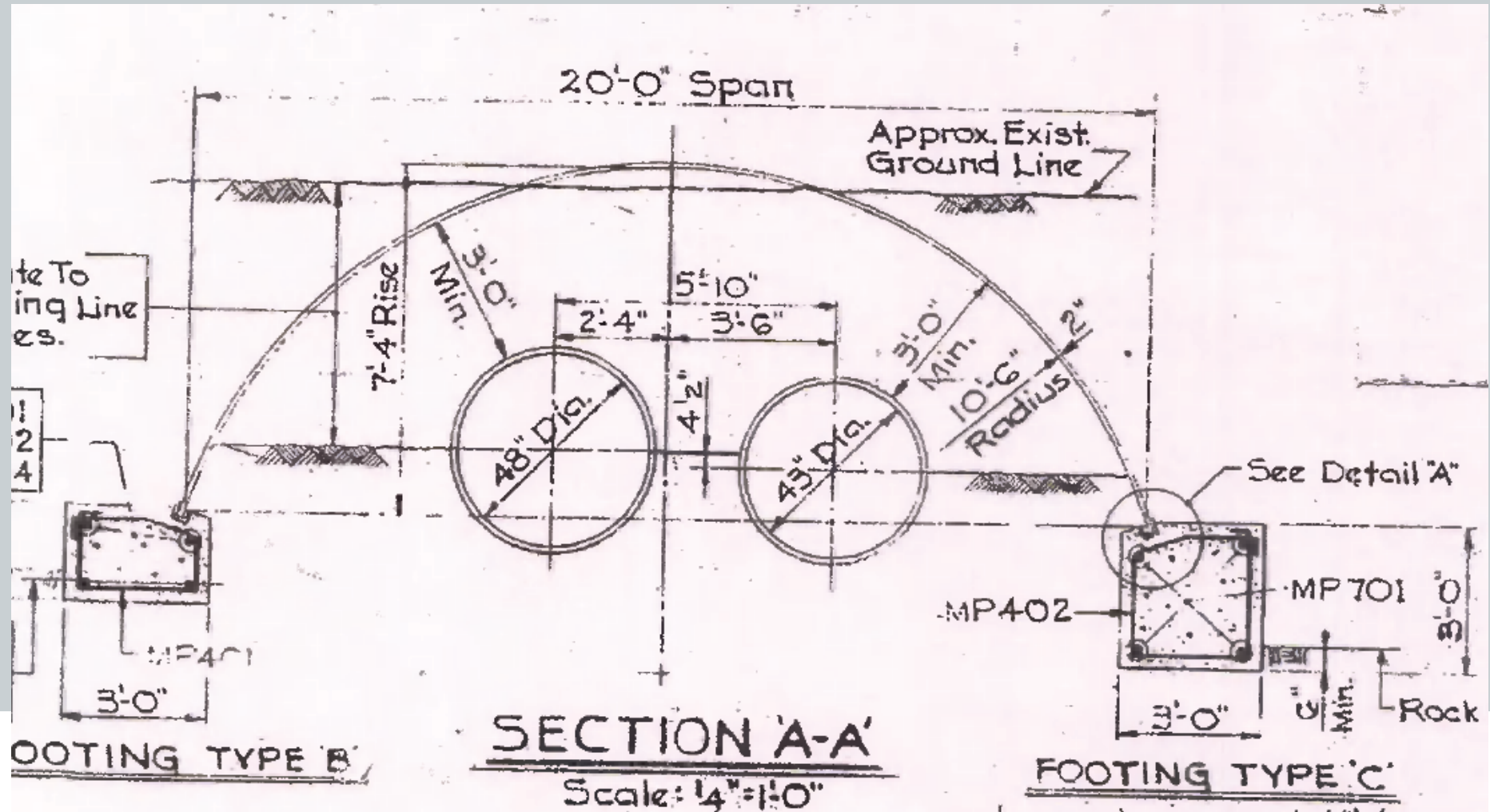

Fig. 11. Lock Bar for Steel Pipe



# Existing Water Mains and Arch →



# I-95 / Route 202 interchange → DeIDOT project

- Projects includes adding lanes to I-95 ramps, realignment and reconstruction of certain ramps, reconstruction of US 202 bridge deck, and repaving of I-95
- New exit/entrance ramps proposed to be installed over unprotected sections of main
- Large amount of fill required for construction  
– additional load on unprotected pipe



# Protection of Existing Mains →

- Planning between City of Wilmington, DelDOT and HMM to determine best method to protect existing water mains
  - Provide casing arch in location of new ramps/ fill
  - Replacement
  - Clean and cement mortar lining
  - Slipline

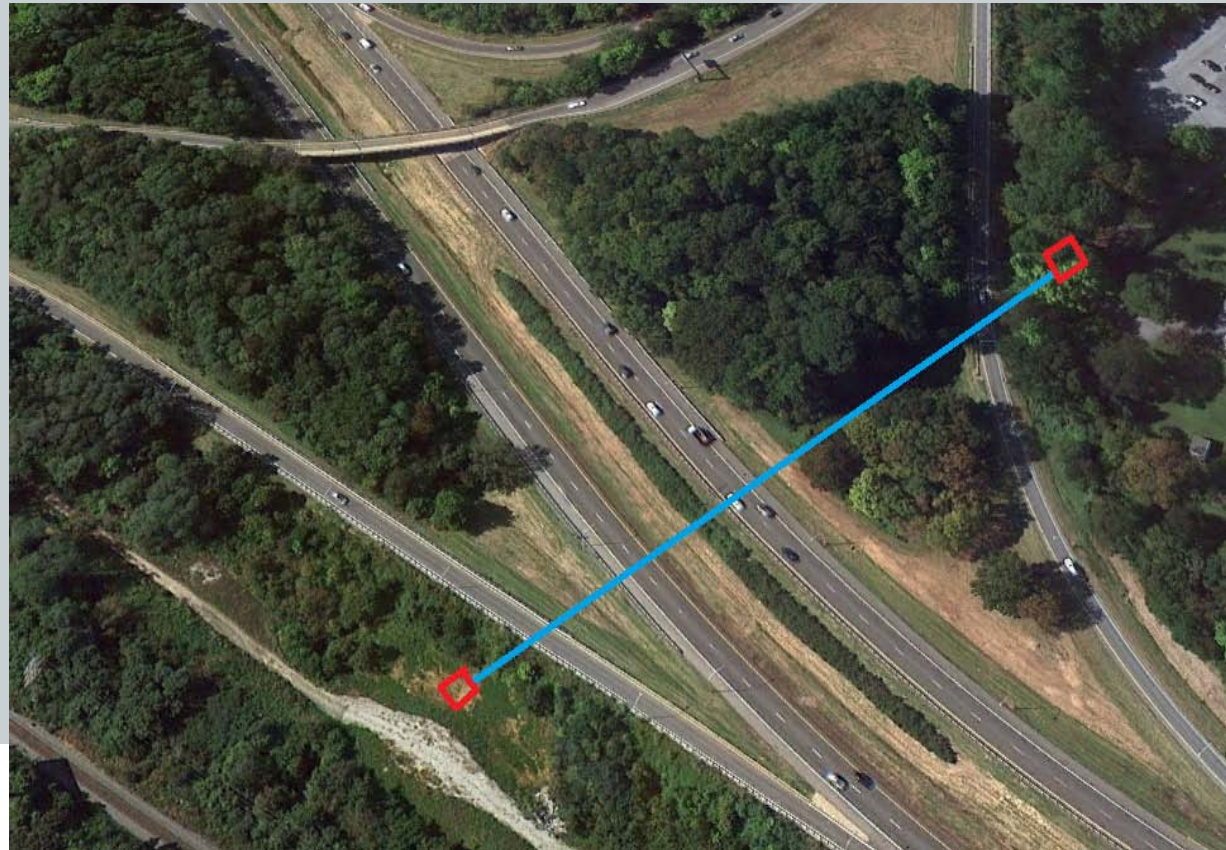

# Initial Inspection of Water Mains →

- The mains were visually inspected during highway construction
  - Mains exposed to determine exterior condition
  - CCTV pipe interior
  - Coupons taken from pipe sample
  - Corrosion analysis





Hatch Mott  
MacDonald

## Pipe Interior →



# Sliplining of Water Mains →

- Sliplining vs. other methods
  - HDPE best track record for sliplining large pipes
  - Greater wall thickness of HDPE to help protect from sharp edges
  - Concerned about the potential stress on pipe when pulling through lockbar pipe – HDPE has best flexibility
  - Fusible PVC not available larger than 36"



- Sliplining vs. Other Materials (cont'd)
  - Fusing of HDPE is proven technique
  - Local contractor and less expensive than other alternatives
  - Less expensive and invasive than replacement
  - Fusible PVC not used for pipes greater than 36 inches in diameter
  - Structural spray lining not yet widely accepted for this application





- Mechanically clean interior of water mains
- Pull HDPE pipe through the existing line
- Hydrostatically pressure test and disinfect water line
- Bacteria test water mains
- Complete connection to existing mains





# Sliplining Cross-Section Detail →

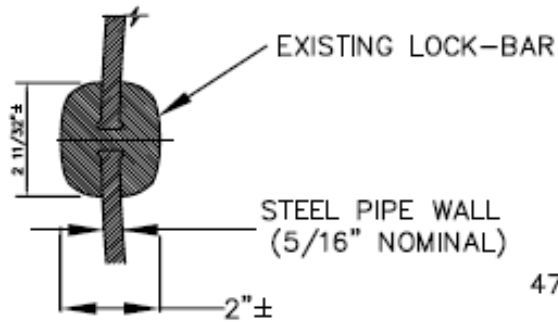

**BLOW-UP B**  
**NOT TO SCALE**

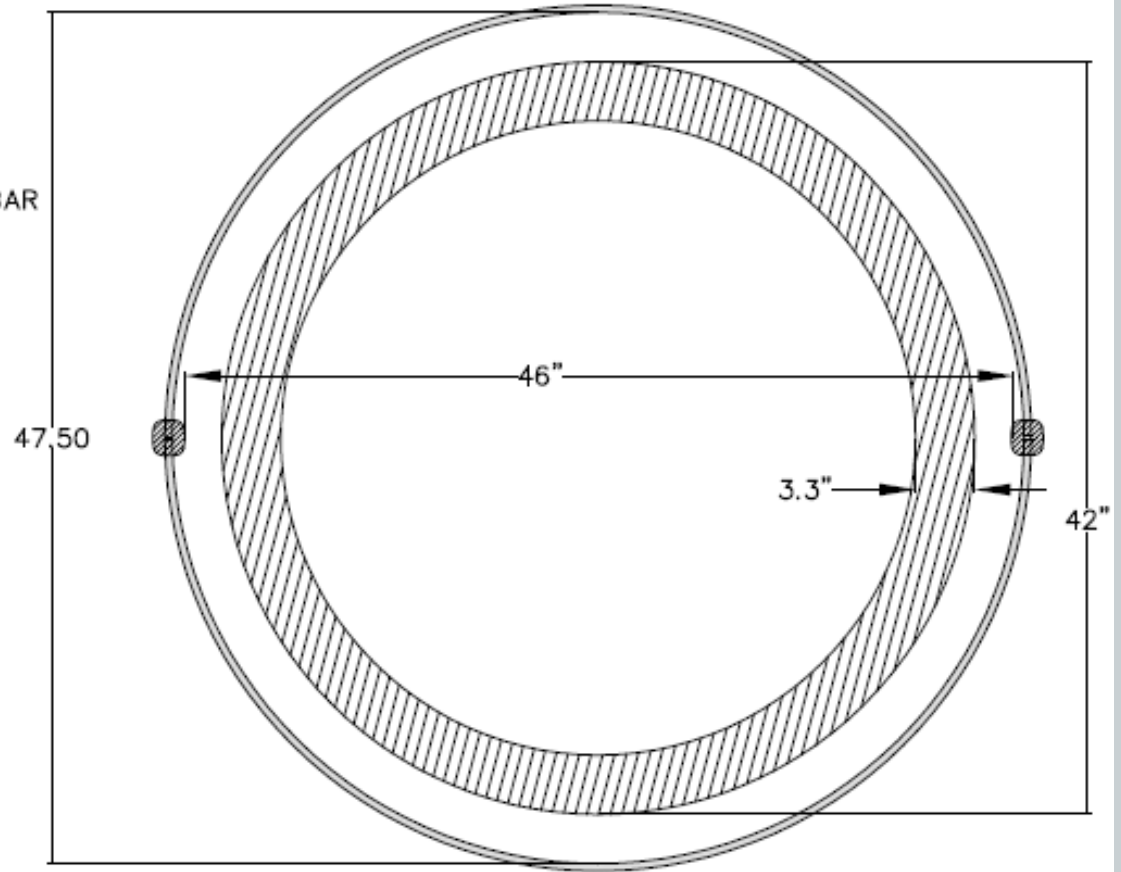

**NOTE:**

ALL DIMENSIONS ARE APPROXIMATE.



Hatch Mott  
MacDonald

# HDPE Cross-section →





Hatch Mott  
MacDonald

## HDPE Fusing Machine →

Polyethylene pipe and fittings are connected by means of butt fusion, which is done by utilizing a fusion machine that holds the pipe &/or fitting in a stationary position. A facer that has a cutting blade then trims the ends to be mated. A heater plate is positioned between the ends to be connected. The heater is then removed and the ends are brought together and allowed to cool.





# Fusing of HDPE Pipes →



# Fusing of HDPE Pipe Sections →





Hatch Mott  
MacDonald

# Fusing HDPE Flange Adapter →

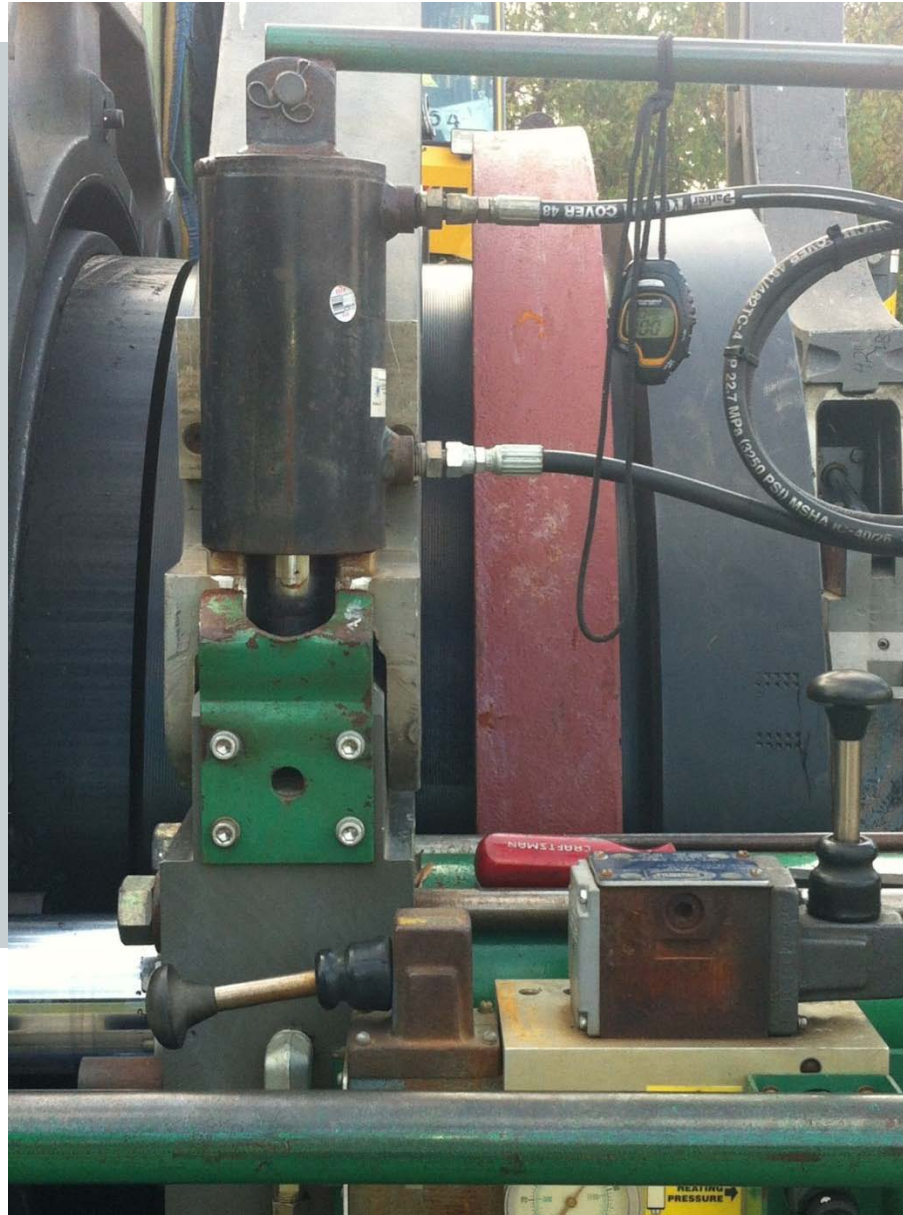



Hatch Mott  
MacDonald

# Connection to Existing Mains →





# Connection to Existing Mains →



# Connection to Existing Mains →

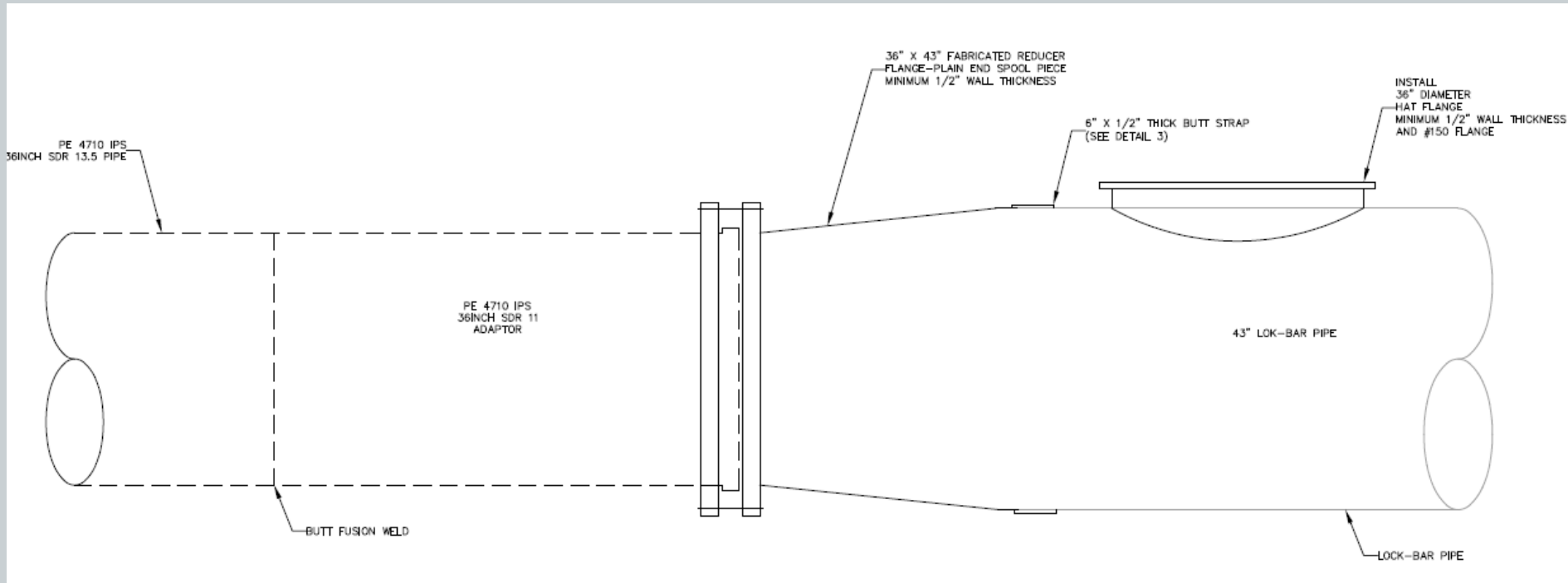

## Challenges of sliplining the mains

- Contraction/ expansion of liner pipe
- Position of existing pipe
  - Receiving pits and lay down area
    - confined area
  - Required fabrication of custom parts to connect the liner pipe to the existing pipe upstream and downstream of the project site
  - Area for pulling pipe through the carrier pipe





- The two water mains were successfully sliplined without major issue
- Pressure testing and bacteria testing of the mains was successful
- The mains will be back in service in a timely manner





Hatch Mott  
MacDonald

