



PLASTICS·PIPE·INSTITUTE

# *PEX Pipes for NFPA 13D Residential Fire Sprinkler Applications*



PLASTICS·PIPE·INSTITUTE

## *Acknowledgement*

This presentation was developed in cooperation with PEX system manufacturing members of the Plastic Pipes Institute (PPI), and PPI would like to acknowledge the work of the task group that developed this industry presentation for residential fire sprinkler applications.



PLASTICS·PIPE·INSTITUTE

# *Why we need Residential Fire Sprinkler Systems*



[http://www.youtube.com/watch?v=gsUuj5gF6-c&feature=player\\_embedded](http://www.youtube.com/watch?v=gsUuj5gF6-c&feature=player_embedded)



## *PEX Pipes for Fire Sprinkler Applications*

- Introduction
- PEX pipe basics
- Reasons for using PEX systems
- Industry standards and tests
- Code acceptance
- PEX joining systems
- Design considerations
- Installation considerations
- Training and certification requirements
- PEX water Supply
- PEX systems for other applications



## *Who is PPI?*

- PPI is the major trade association representing all segments of the plastics piping industry
- PPI is dedicated to promoting the safe use of plastic piping systems through:
  - Contributing to development of standards
  - Educating designers, installers, users and government officials
  - Establishing a forum for problem solving and new ideas
  - Maintaining liaison with industry, educational and government groups
- PPI has five divisions: Municipal and Industrial, Corrugated Polyethylene Pipe, Fuel Gas, Conduit, Building and Construction



## *Building and Construction Division: Mission Statement*

- To promote the expanded acceptance and use of high reliability plastic pressure pipe and tubing systems in building and construction environments by providing research, education, and code/standard development with a focus on delivering sustainable and safe plastic system solutions that enrich people's lives.



## *Building and Construction Division: Members - Manufacturers of PEX Pipes*

- REHAU
  - Uponor
  - Viega LLC
  - Zurn Pex, Inc.
  - Golan Plastics
  - BOW Plastics
  - IPEX
  - JM Eagle
  - Mercury Plastics
  - NIBCO
  - Reliance Worldwide USA
  - Watts Water Technologies
- Other members include manufacturers of PERT, CPVC, PPr, polyethylene resin, compounds, and additives; test laboratories; consultants. Please visit [www.plasticpipe.org](http://www.plasticpipe.org) for a complete list of members



PLASTICS·PIPE·INSTITUTE

## *PEX Pipes for NFPA 13D Residential Fire Sprinkler Applications - Introduction*

- Fire is the single largest cost of property loss in the United States. According to the National Fire Protection Association (NFPA) fire damage caused \$7.4 billion worth of residential property loss in the U.S. in 2007
- According to the Home Fire Sprinkler Coalition 8 out of 10 fire deaths occur in the home
- Residential fire sprinklers systems are primarily designed to *save lives* by providing adequate time for occupants to exit the area experiencing a fire
- PEX is approved for use in residential sprinkler applications with the acceptance of UL 1821 and NFPA 13D





## *PEX is Cross-linked (X) Polyethylene (PE) Description from PPI TN-17 (2008)*

- PEX is a polymeric material formed by the chemical joining of individual polyethylene molecules in a process called crosslinking.
- Crosslinking alters the performance of the original polyethylene polymer improving several key properties.
- The primary reason for crosslinking polyethylene (PE) is to increase the material's elevated temperature performance under load.
- In addition, crosslinking substantially improves the pipe's environmental stress crack resistance (ESCR), resistance to slow crack growth, chemical resistance, toughness and abrasion resistance.



## *How is PEX Pipe made?*

- PEX tubing is produced and certified to ASTM F876
- There are 3 primary commercial processes; each with a proven history of performance:
  - High-pressure peroxide
  - Silane (moisture cure)
  - Electron Beam
- Each method is proven to make product that meets the strict requirements of US and International standards and other organizations (ASTM, CSA, UL, ISO).



## *PEX Products*

- PEX pipes are produced in nominal dimensions from 3/8" to 4" today in USA (even smaller sizes for special applications).
- PEX pipes are available in natural (white) or colors such as red, blue, black and purple.
- PEX pipes are available in coils or straight lengths, depending on the application.





PLASTICS·PIPE·INSTITUTE

## *Why use PEX Pipes?*

- Proven history of performance
- Smooth interior reduces pressure loss
- Corrosion resistance
- Reliability
- Flexibility in design and installation
- Approved in IRC, NFPA 13D and all model plumbing codes
- More than 30 years of experience worldwide in potable water applications
- A Green solution!





## *Engineering Benefits:*

1. Resistance to corrosion, erosion, water disinfectants
2. Resistance to oxidative and chemical attack
3. Resistant to failure from freezing
4. A sustainable product with green benefits (i.e.: water conservation, durability, lower production and transportation costs)
5. High-temperature capability, pressure-rated up to 200° F
6. High-pressure capability/stability (reduced creep)
7. Smooth wall, excellent flow characteristics
8. Quiet operation, absorbs pressure surges (reduced water hammer)
9. Flexibility for efficient design of piping layouts
10. Proven long life, rigorous certifications, stringent testing



PLASTICS·PIPE·INSTITUTE

## *Engineering Benefits: Hydrostatic Strength*

- Minimum strength according to ASTM F876 and CSA B137.5:
- Minimum Short-term Burst Strength
  - 475 psi @ 73.4°F (3,310 kPa @ 23°C)
  - 210 psi @ 180°F (1,450 kPa @ 82°C)
  - 180 psi @ 200°F (1,240 kPa @ 93°C)
- Long-term Pressure Ratings
  - 160 psi @ 73.4°F (1105 kPa @ 23°C)
  - 100 psi @ 180°F (690 kPa @ 82°C)
  - 80 psi @ 200°F (550 kPa @ 93°C)

*Note: Temperature/Pressure ratings are based on an extrapolated time-to-failure prediction as defined in ASTM D2837, with a Design Factor of 0.50 on pressure*



## *Engineering Benefits:*

- PEX is corrosion resistant (PEX is a non-conductor so electrolysis is simply not possible with PEX)
- No build-up of minerals inside the pipe, which could reduce flow over time

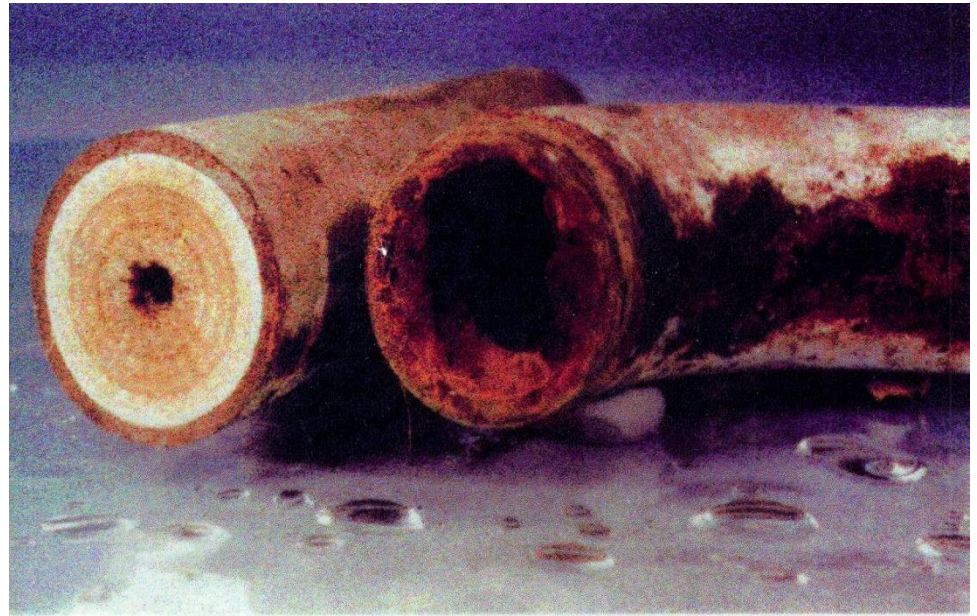



## *Engineering Benefits:*

- No pinhole problems characteristic of metal pipes
- No erosion corrosion **issues** with PEX pipes or plastic fittings
  - See PPI TN-26 “Erosion Study of Brass Insert Fittings used in PEX Piping Systems”
- PEX piping systems using brass, bronze, stainless steel, and plastic fittings are more tolerant of higher flow velocities than all copper systems







## *Engineering Benefits:*

- PEX pipes are resistant to failure from freezing and can withstand repeated freezing of water without damage
  - Burch, J., et al. (2006). *Northward market extension for passive solar water Heaters by using pipe freeze protection with freeze-tolerant piping*. National Renewal Energy Lab, NREL/CP-550-39664





## *Installer Benefits:*

- Flexible pipe with reduced number of fittings allows faster installation
- Greater flexibility for design options
- Secure, reliable fittings reduce leaks
- Lightweight material, easy and safe to transport and handle
- Efficient to install, long coils reduce waste and number of joints
- Clean and safe to work with





## *Home Owner Benefits:*

- Proven safety benefits
- Proven long life of PEX systems
- Non-toxic, safe for hot and cold drinking water
  - many PEX fire systems are multi-purpose/integrated with the plumbing system
- Quiet, dampens water hammer and pressure surges
- Resistant to failure from freezing
- Lower cost installations
  - (average 1 – 1 ½% of total construction cost)
- Reduced property loss
  - \$14,000 per fire in homes with sprinklers vs. \$179,896 per fire in homes without sprinklers
- Reduced water use and damage
  - Homes with fire sprinklers used 340 gallons per fire vs. 5974 gallons for homes without sprinklers according to a 2011 Bucks County, PA study.



## *Builder Benefits:*

- Proven long life
- Corrosion resistant
- Non-toxic, safe for hot and cold drinking water
- Quiet, dampens water hammer and pressure surges
- Lower thermal conductivity than copper reduces probability for condensation
- Resistant to failure from freezing
- Lower cost installations
  - (average 1 – 1 ½% of construction cost)



PLASTICS·PIPE·INSTITUTE

## *Inspector Benefits*

- Proven performance
- National System Listings and Code Approvals
- Complete training offered by system suppliers
- Simple system testing with visual inspection, pressure test, and flow test



PLASTICS·PIPE·INSTITUTE

## *The Benefits of Home Fire Sprinklers*

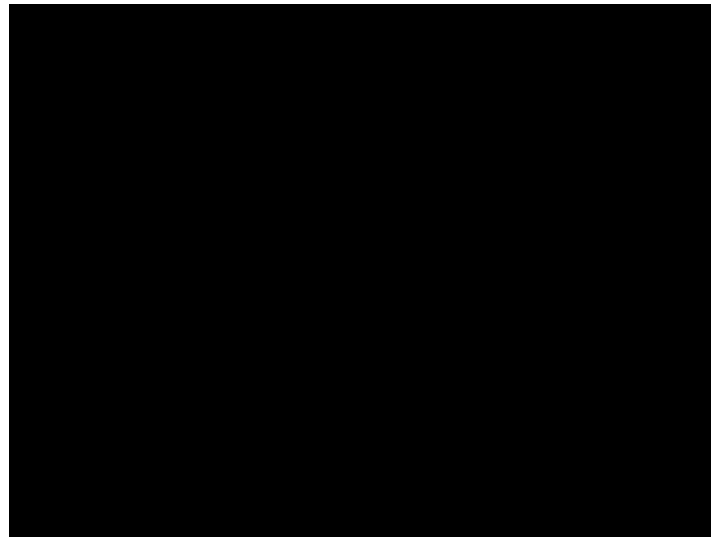

[http://www.youtube.com/watch?v=NtBafQdE9AM&feature=player\\_embedded](http://www.youtube.com/watch?v=NtBafQdE9AM&feature=player_embedded)



PLASTICS·PIPE·INSTITUTE

# *PEX System Standards, Testing, and Code Acceptance*



## *Standards for PEX and PEX Systems*

- ASTM F876 – Materials, Dimensions and Performance for Tube
- ASTM F877 – Performance Standard for Tube/Fitting Systems
- ASTM F2023 – Chlorine Resistance test method
- ASTM F2657 – UV Resistance test method
- AWWA C 904 – Standard for PEX service lines
- NSF/ANSI Standard 14 – Plastic Piping System Components and Related Materials
- NSF/ANSI Standard 61 – Toxicological Evaluation for Materials in Contact with Drinking Water; “Health Effects”
- NSF/ANSI 372 – Drinking Water System Components, Lead Content
- NSF/ANSI 359 – Valves for PEX Water Distribution Systems
- Multiple ASTM fitting standards
- UL 1821 – Thermoplastic Sprinkler Pipe and Fittings for Fire Protection Service





## *PEX Pipe Requirements*

- ASTM F876 “Standard Specification for Crosslinked Polyethylene Tubing”
  - Pipes are CTS, SDR9, with tight tolerances on dimensions
  - Long-term Pressure Rating of 130 psi @ 120°F for fire sprinkler applications. Also rated at:
    - 160 psi @ 73.4°F, 100 psi @ 180°F, 80 psi @ 200°F
  - Minimum Quick Burst Capability:
    - 475 psi @ 73.4°F, 210 psi @ 180°F, 180 psi @ 200°F
  - Sustained Pressure Tests
    - Up to 16,000 hours accelerated laboratory hydrostatic testing is required for PPI “Standard Grade” listings



## PEX Pipe Requirements

- ASTM F876 has categories for performance in three key properties
- Performance categories are defined in the “Material Designation Code”
  - Example shown from ASTM F876

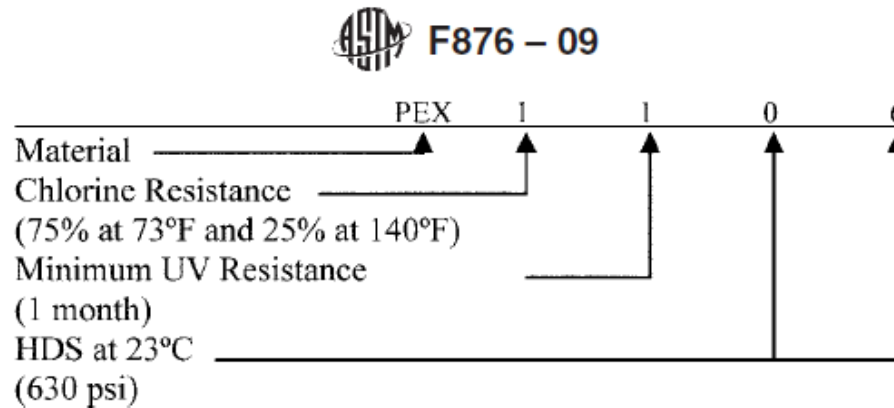

For example ASTM F876 PEX tubing marked with the material designation code PEX 1106 is a PEX tubing meeting the chlorine resistance requirement for 25% of the time at 140°F and 75% of the time at 73°F having a Minimum UV resistance of 1 month and having an HDS for water at 73°F of 630psi (HDB of 1250 psi).



## *Chlorine and Chloramine Resistance*

- ASTM F2023 “Standard Method for Evaluating Resistance to Hot Chlorinated Water” is the test method
  - Minimum Oxidation reduction Potential (ORP) 825 mV (typical of 4.0 ppm chlorine, pH 6.8)
  - 50 year minimum extrapolated life at 80 psig pressure
- It has been shown that chloramines are less aggressive than free chlorine to PEX pipes, and that testing using free chlorine, in accordance with ASTM F2023, will conservatively estimate the time-to-failure for PEX pipes when used with the disinfectant chloramines.”
  - See PPI Statement A: “Relative Oxidativeness of Chloramines and Free Chlorine Disinfectants...on PEX Pipe”



## *UV Resistance*

- PEX UV resistance determined by ASTM F2657 “Standard Method for Outdoor Weathering Exposure of Crosslinked Polyethylene”
  - Pipes are exposed in desert near Phoenix, AZ for natural UV radiation exposure for specified time periods
  - Exposed pipes are then re-tested for F2023 chlorine resistance to show no significant reduction in pipe lifetime
  - Manufacturer reports acceptable UV exposure limits based on this testing, in accordance with ASTM F876
- ASTM F876 has four categories for UV resistance, as part of the Material Designation Code:
  - 0:** Not tested or not rated
  - 1:** 1 month
  - 2:** 3 months
  - 3:** 6 months



## *PEX System Requirements:*

- ASTM F877 “Standard Specification for Crosslinked Polyethylene Plastic Hot- and Cold- Water Distribution Systems”
  - Applies to pipes with fittings and/or manifolds, tested as systems
  - Quick burst capabilities, sustained pressure requirements
  - Excessive Temperature and Pressure test:
    - 150 psi @ 210°F for 720 Hrs. (30 days)
  - Thermocycle Test:
    - Pressurize with 100 psi Nitrogen gas
    - 2 Minutes in 60°F water, 2 Minutes in air, 2 Minutes in 180°F water
    - Repeat 1,000 times with no leaks



## *Joining: Mechanical Fitting Systems*

- ASTM standard specifications for PEX fittings:
  - ASTM F1807: Brass or Copper Insert Fittings with Copper Crimp Rings
  - ASTM F1960: Cold Expansion Fittings with PEX Reinforcing Rings
  - ASTM F2080: Cold Expansion Fittings with Metal Compression-Sleeves
  - ASTM F2098: Stainless Steel Clamps for Use with F1807 Insert Fittings
  - ASTM F2159: Plastic Insert Fittings using Copper Crimp Rings
- ANSI/UL 1821 Listed PEX Fittings Systems
  - ASTM F1807: Brass or Copper Insert Fittings with Copper Crimp Rings
  - ASTM F1960: Cold Expansion Fittings with PEX Reinforcing Rings
  - ASTM F2080: Cold Expansion Fittings with Metal Compression-Sleeves
  - ASTM F877: PEX Hot- and Cold Water Distribution Systems



## *Pressure Rating for Fire Sprinkler Plastic Pipe and Fittings System*

	Minimum Rated Pressure	Minimum Rated Temperature
UL1821	175 psi	120F
UL1821 (NFPA 13D for multipurpose and standalone systems in certain applications)	130 psi	120F
Typical plastic pipe rating for hot and cold water distribution systems	100 psi	180F



# UL 1821 Testing Protocol for Fire Sprinkler Plastic Pipe and Fittings System

UL1821	Test	tubing	fitting	system
section 14	Pipe coefficient of friction	x		
section 15	Fitting equivalent length			x
section 16	Crush resistance	x		
section 16A	Stress corrosion cracking of SS parts		x	
section 17	Flexural test			x
section 18	Impact resistance test	x		
section 19	Vibration test			x
section 20	High pressure sprinkler operation			x
section 21	Kinking test	x		
section 22	Assembly test			x
section 23	Hydrostatic pressure test			x
section 24	Pressure cycling test			x
section 25	Temperature cycling test			x
section 26	10 day moist ammonia air stress cracking		x	
section 27	Long term hydrostatic			x
section 28	Environmental exposure			
	Water immersion			x
	Air oven aging			x
	Light and water	x		
section 29	Marking permanency	x		

\* The fire exposure testing is exempted if the piping material is protected by as 3/8" thick gypsum wall board or 1/2" thick plywood or other equivalent system. Reflects as a listing footnote.





## *Code Acceptance*

- Listed PEX meets NFPA 13D and IRC P2904 requirements
- PEX is listed as an acceptable material in all national model plumbing codes (ICC, IRC, UPC, and NSPC)
- Always confirm acceptability with AHJ



PLASTICS·PIPE·INSTITUTE

## *US Adoption of IRC*

- PEX is listed in International Residential Code (IRC) Section P2904 - Dwelling Unit Fire Sprinkler Systems
- ICC including IRC code adoption by State available at: [www.icc.org](http://www.icc.org)
- More than 400 jurisdictions in the United States now require fire sprinklers in single family homes



PLASTICS·PIPE·INSTITUTE

# *Design of PEX Residential Fire Sprinkler Systems*



PLASTICS·PIPE·INSTITUTE

## *Designing PEX Fire Sprinkler Systems*

- PEX can be used in multipurpose, passive purge and stand-alone systems as defined by NFPA 13D
- PEX is flexible so an installation looks different than an installation with rigid pipe.
- Refer to PEX manufacturer's Installation Guides
- Note: Residential fire sprinklers systems are primarily designed to *save lives* by providing adequate time for occupants to exit the area experiencing a fire.

2013

**NFPA 13D**

**Standard for the  
Installation of Sprinkler Systems  
in One- and Two-Family  
Dwellings and Manufactured Homes**

**13D**





## *PEX Fire Sprinkler Design Process*

1. Identify local jurisdiction requirements including building, fire, and plumbing codes
2. Understand the type of residence or “use group classification”
3. Identify water supply source and available flow and pressure
4. Identify water supply service including elevation differences
5. Determine sprinkler head specifications including: flow, pressure requirements, and coverage area
  - Note: Sprinklers must be listed for residential applications (with a few specific exceptions)
6. Lay out piping system
7. Perform hydraulic calculations on the system design
  - Note that NFPA 13D establishes required design criteria
  - Check with local AHJ regarding specific credentials (NICET III or PE)



PLASTICS·PIPE·INSTITUTE

# *Types of Sprinkler Heads*

## *Concealed Sprinklers*

- These sprinklers are flush against the ceiling and are covered with a special cover plate. In operation, the plate falls off at approximately 135°F and as the heat increases the sprinkler operates. It is important to **never** paint over the special cap. It may interfere with the operation of the sprinkler.



Flush concealed sprinklers

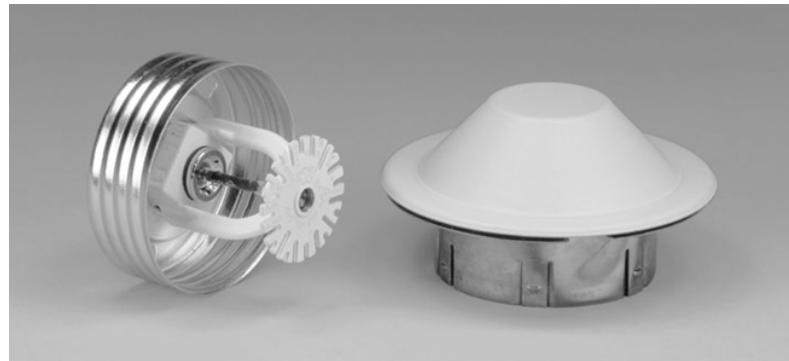

Domed Concealed Recessed  
Pendent Sprinklers



PLASTICS·PIPE·INSTITUTE

# *Types of Sprinkler Heads*

## *Recessed Pendent Sprinklers*

- These sprinklers are visible on the ceiling and do not have a cover plate. In operation, high heat in the range of 150°F to 175°F will cause the sprinkler to operate.



Recessed Pendent Sprinklers



PLASTICS·PIPE·INSTITUTE

# *Types of Sprinkler Heads*

## *Horizontal Sidewall Sprinklers*

- These sprinklers are visible on the wall and do not have a cover plate. In operation, high heat in the range of 150°F to 175°F will cause the sprinkler to operate.



Horizontal sidewall sprinklers





## *Multipurpose Fire Protection Systems*

- Examples of multipurpose systems are provided in the Annex of NFPA 13D. Common to each system is the connection of domestic fixtures to the piping serving the fire sprinklers. Piping configurations may be combined for improved efficiency and hydraulic performance.
  - Looped – sprinklers on each floor level are connected in a loop so they are supplied from two sides; branch lines to supply additional sprinklers are allowed
  - Gridded – similar to looped systems, with inter-connected “sub-loops” to serve additional sprinklers; provides excellent hydraulic characteristics due to multiple supply paths
  - Tree – also known as “trunk and branch”, sprinkler heads are served by a single line; usually requires larger piping to meet hydraulic demands
  - Passive Purge – systems designed to serve the fire sprinkler system and a single toilet



# PEX Fire Sprinkler Systems – Loop Layout

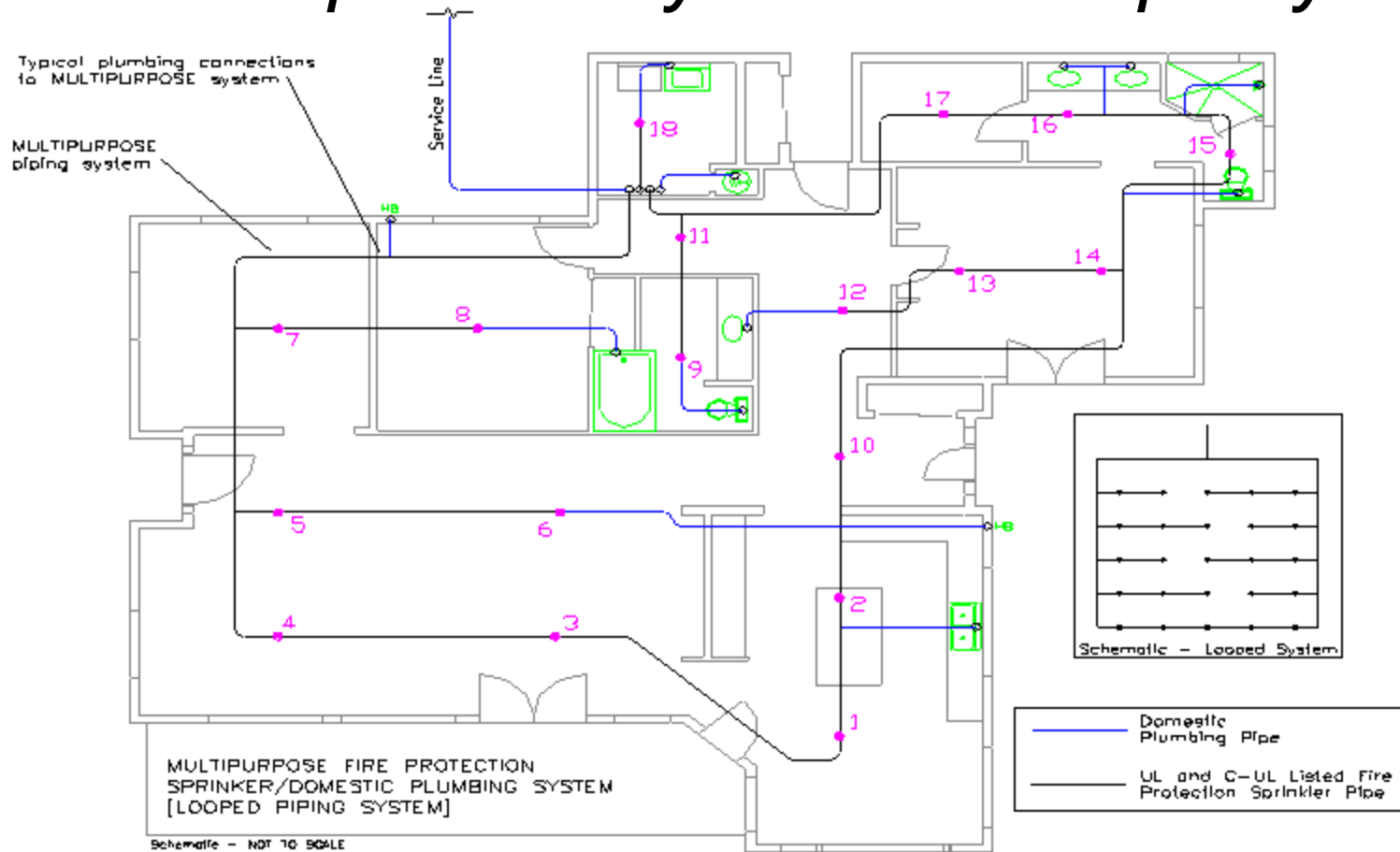



# PEX Fire Sprinkler Systems – Loop

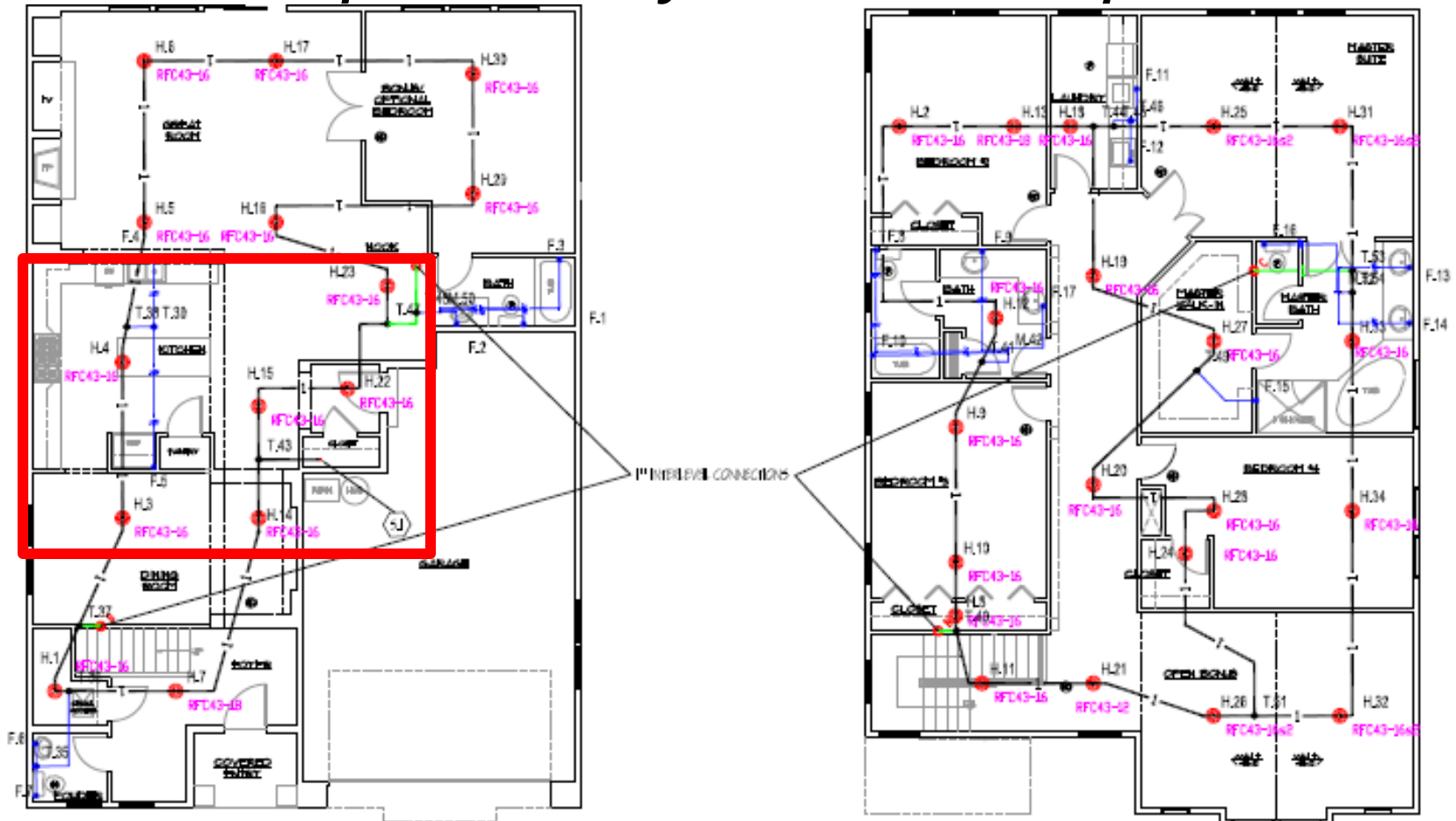



# PEX Fire Sprinkler Systems – Grid

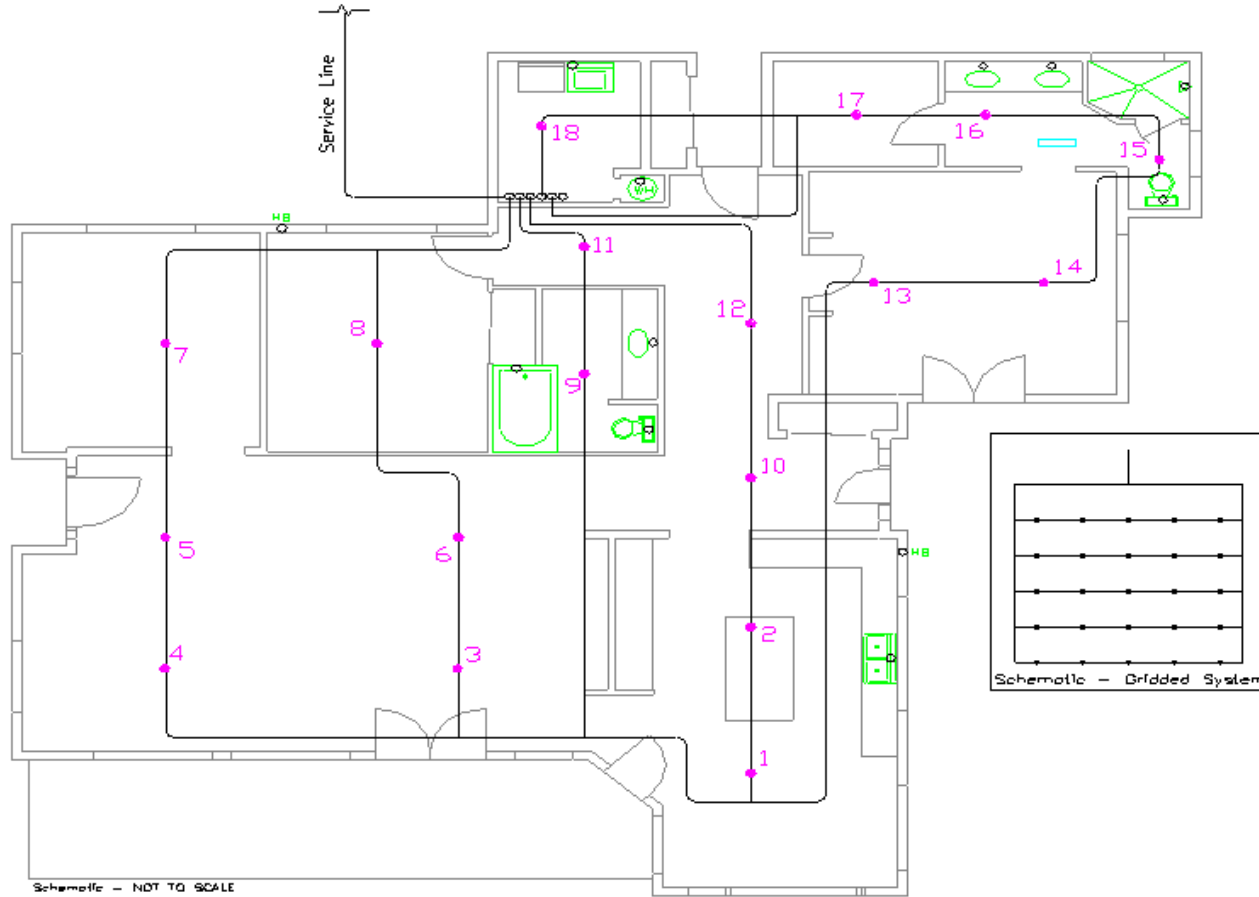



# PEX Fire Sprinkler Systems – Multipurpose

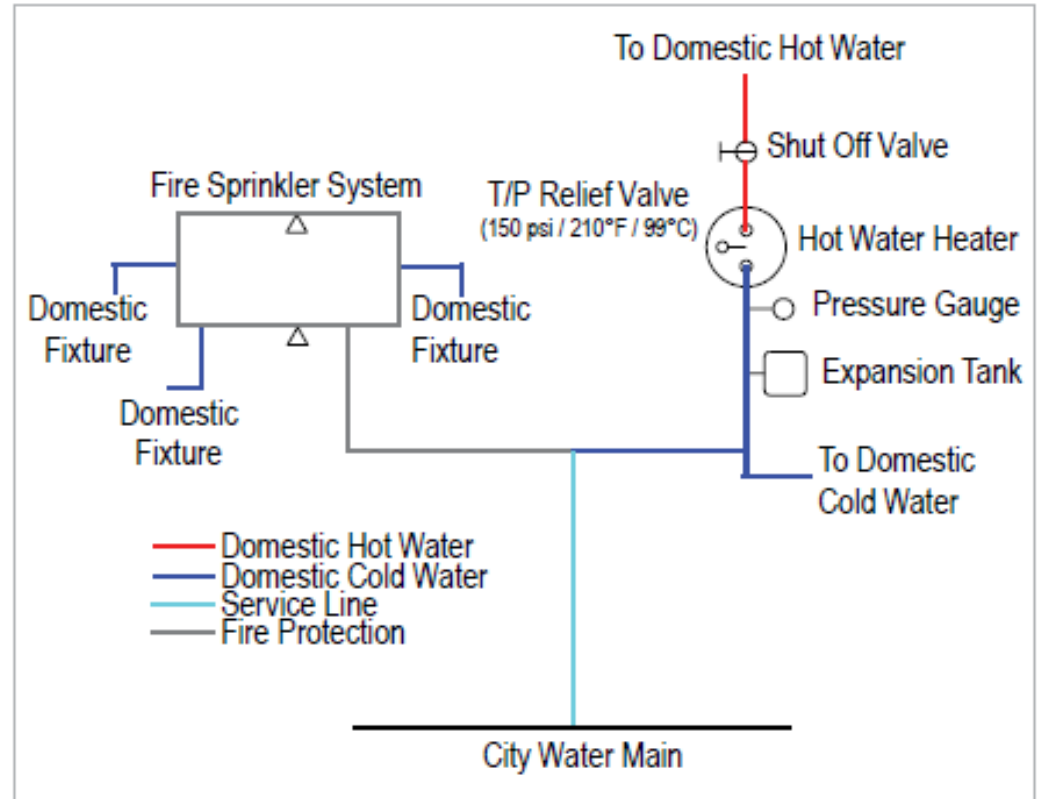

Local code requirements will determine exact configuration. Check with the AHJ to define what constitutes a multipurpose system in your local area.



# PEX Fire Sprinkler Systems – Passive Purge

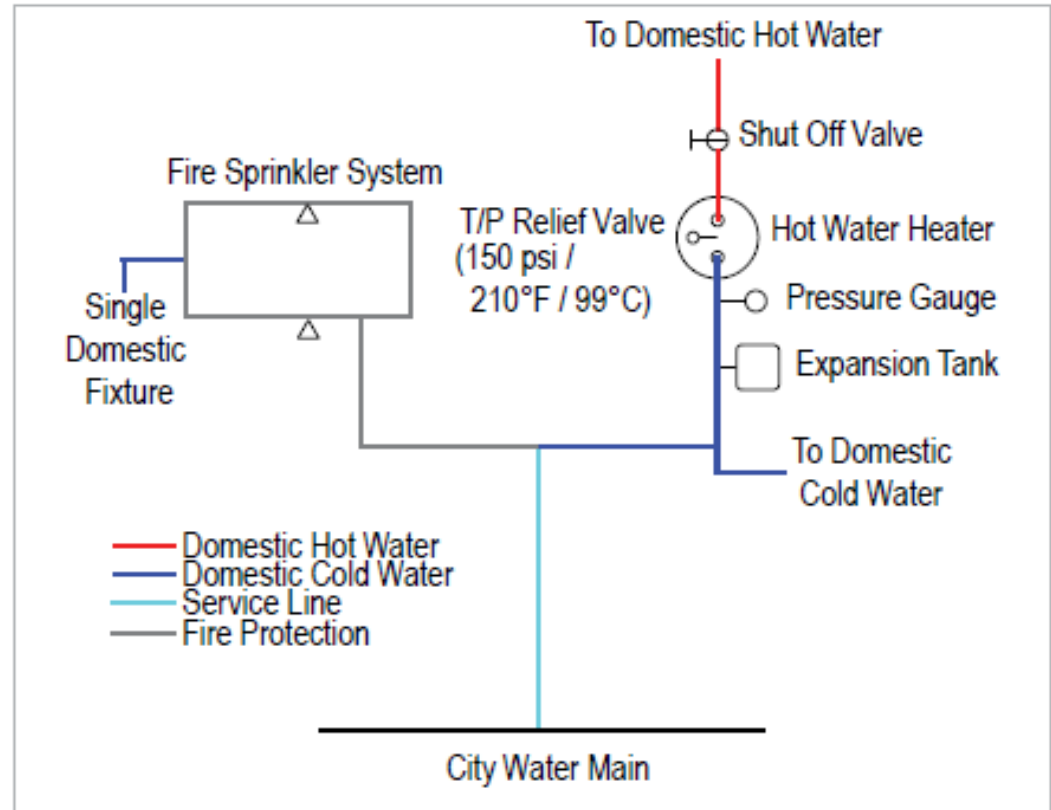

Local code requirements will determine exact configuration. Check with the AHJ to define what constitutes a multipurpose system in your local area.



# PEX Fire Sprinkler Systems – Stand-alone

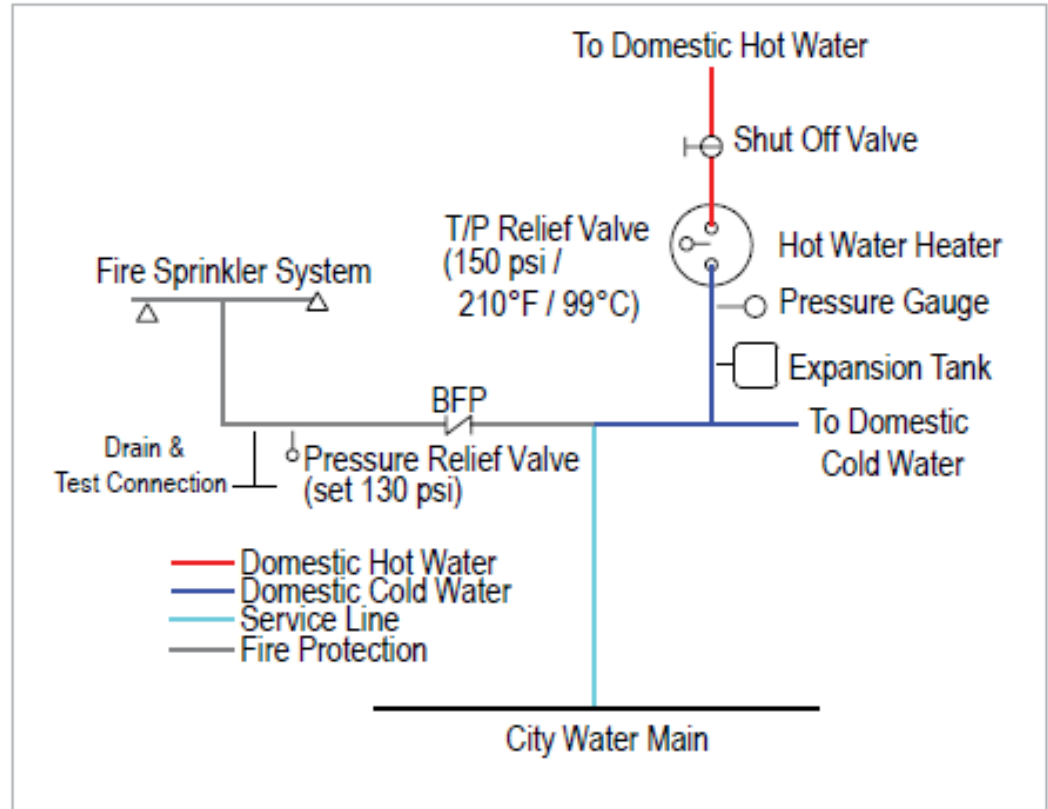

Local code requirements will determine exact configuration. Check with the AHJ to define what constitutes a multipurpose system in your local area.



PLASTICS·PIPE·INSTITUTE

# *PEX Installation Practices*





## *PEX Installation Basics*

- Consult with Manufacturer's Literature for recommended minimum bending radius.
- Horizontal runs should be supported every 32 inches for sizes  $\leq 1''$ 
  - Manufacturers will allow up to 48" on larger diameters.
- Vertical runs should be supported every 60 inches.





## *PEX Installation Basics*

- Protect PEX from abrasion
  - Use sleeves or plastic isolators through metal studs (not required in wood studs)
- Use hangers that are smooth without sharp edges - plastic is preferred
- Hangers should not pinch the tube
- Use protective nail plates where PEX passes within 2" of a nailing surface on a stud





## *Linear Expansion and Contraction*

- Linear expansion rate of PEX: 1 inch per 10°F per 100 ft. length
- Example: Hot water pipe 50 ft. long, 50°F rise will lengthen pipe by 2.5 inches
- Installers must allow for movement with correct installation
- In systems with wide temperature swings using larger diameters of PEX ( $\geq 1$ " ) deflection legs may be required to accommodate expansion/contraction of pipes without excessive force on fittings and fixed brackets





## *Linear Expansion and Contraction*

- Additional expansion allowance methods shown below

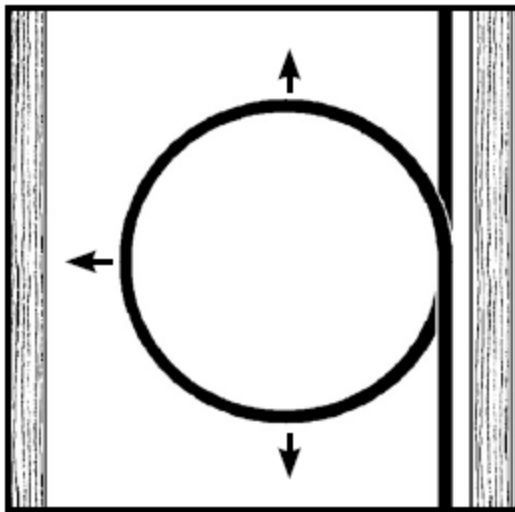

*Using a loop to accommodate tubing expansion*

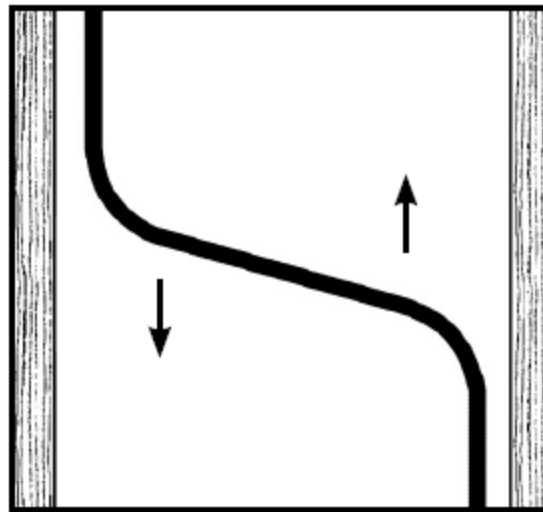

*Offsets also provide room for tubing expansion*



PLASTICS PIPE INSTITUTE

## *Piping through floor joists and wooden studs*





PLASTICS PIPE INSTITUTE

## *Piping through floor joists and wooden studs*





## *System Pressure Testing*

- Pressure test as required by manufacturer or code
- Air or water test acceptable
  - PEX is ductile and has a minimum burst pressure of 475 psig
  - PEX pipe will not shatter or create shards if burst
- Maximum test pressure up to 200 psig with water
- Compressed air tests shall include appropriate safety precautions and the test pressure shall not exceed manufacturer's recommendations.
  - Caution: Plastic fittings or other system components, or unassembled fittings, may cause a hazard. Check with local codes before using air pressure testing.
- Flow test in accordance with manufacturer and AHJ requirements





## *System Maintenance*

- NFPA recommends a monthly inspection including:
  - Visual inspection
  - Smoke Alarm testing
  - Sprinkler head integrity
  - Check system pressure
  - Ensure main shutoff valve is open
  - Verify water supply
  - Inspect booster pumps if needed





## *Case Studies and Other Publications*

- Case studies of PEX fire sprinkler installations are available from PEX manufacturers
- NIST Study 7451: “Benefit-Cost Analysis of Residential Fire Sprinkler Systems”
- NIST Study 7277: “Economic Analysis of Residential Fire Sprinkler Systems”
- PPI Technical Note 17: “Crosslinked Polyethylene Pipe and Tubing”
- PPI Technical Note 39: “Recommended Practices Regarding Application of Pesticides and Termiticides Near PEX Pipes”



## *PEX Pipes - Summary*

- Clean, safe water
- Corrosion resistance
- Reliable pipes and fittings
- Resistant to failure from freezing
- Flexibility in design and installation
- More than 30 years of experience
- PEX pipes now available up to 3" diameter
- A sustainable product with green benefits



## *Other Applications for PEX Pipes*

- Plumbing
- Radiant heating and cooling
- Hydronic (hot-water) building services piping (as per ASME B31.9)
- Outdoor snow and ice melting
- Water reuse and reclamation
- Renewable energy
- Insulated energy transfer pipes

