



HDPE
MUNICIPAL
ADVISORY
BOARD



JCM INDUSTRIES

**Fittings and Fabrications
Designed and Engineered
for
High Density Polyethylene Pipe**

**Ron Collins, President
JCM Industries, Inc.**



JCM's experience with HDPE begins prior to 1976 when JCM founder James C. Morriss, Jr. encountered HDPE in the mining and industrial markets. As a product design engineer, he understood that HDPE pipe development was up and coming for the waterworks industry – so the working characteristics of HDPE were taken into consideration during the design stage and launch of JCM's Product Line.

“HDPE Was Born To Be Fused”

JCM recommends fusion joints as a primary method of connection. When correctly implemented, fused joints are self-restraining and leak proof. In some instances conditions are not conducive to properly fuse the joint per manufacturers' recommendations. Mechanical fittings to join or repair HDPE are a secondary and limiting choice.

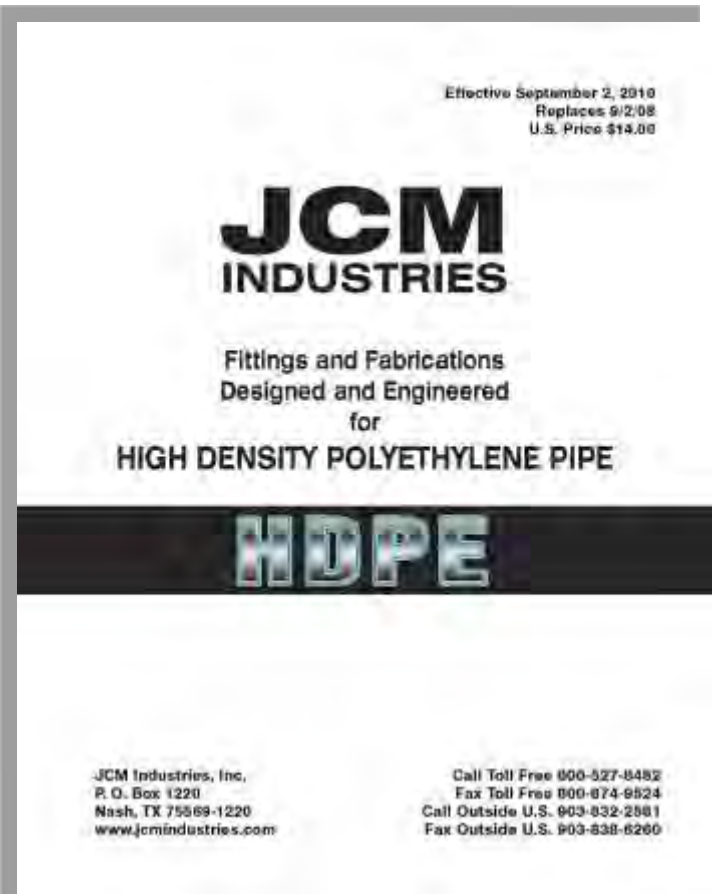
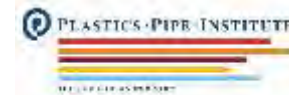

JCM was involved early with the water market HDPE.

JCM worked closely with pipe manufacturers (Chevron Plexco, Phillips Drisco, Quail and others) in educating their pipe sales force in applications with mechanical products.

JCM was called upon so often, that in 1993 we compiled our presentation information and published the first JCM Manual **“Fittings and Fabrications for High Density Polyethylene Pipe.”**

JCM continues to revised, update and publish this manual that features the products recommended, their design concepts that specifically address HDPE, and product application information.

Manual can be provided in hard copy or is downloadable from www.jcmindustries.com



1. Overview of available products recommended for use on HDPE

a) Two Sections

3/4" – 3" CTS, IPS – not available

4" – 12" and larger DIPS and IPS readily available



b) When should JCM Products be used for *potable water HDPE systems*?

JCM bolt on products should be implemented when fusion is not an option. It is JCM's policy to recommend a fusion application if at all possible. Bolt on products should be a secondary method of repair, connection or branching.

c) Provide sample flow chart/decision tree analysis:

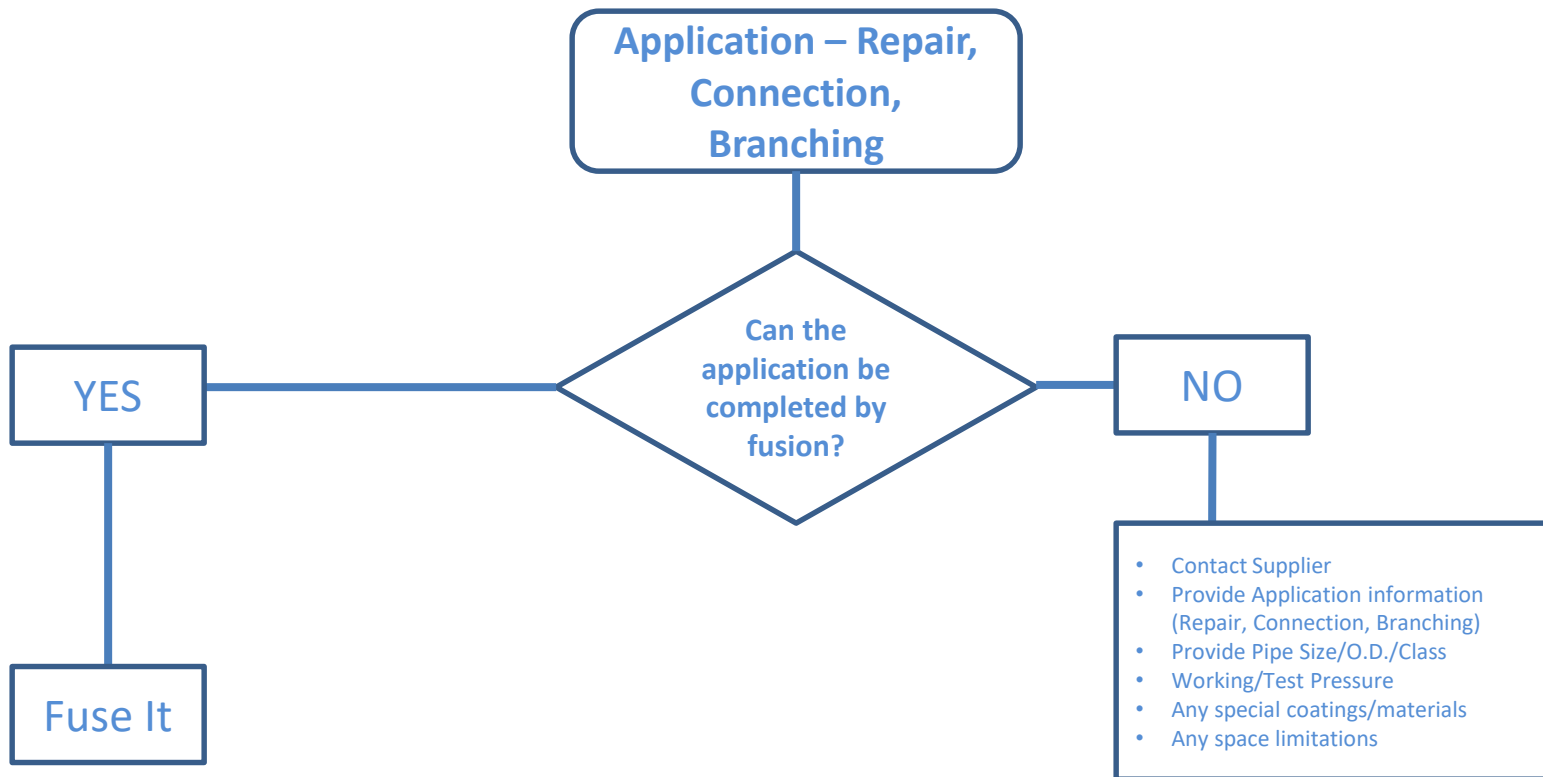



d) Identify Types(s) of Products:

**Repair – Connection – Tapping – Line Stopping
Sizes 4” – 12” and larger**

- **Universal Clamp Couplings**
- **Bolted Couplings/Flanged Adapters**
- **Service Saddles**
- **Tapping Sleeves/Line Stop Sleeves**
- **Fabricated Repair Sleeves**
- **Restrainers**
- **Stainless Steel Pipe Stiffeners (inserts)**

- **Sizes 4” and larger**



HDPE
MUNICIPAL
ADVISORY
BOARD



Overview - JCM Universal Clamp Couplings

JCM recommends the featured models for use on HDPE Pipe

JCM 101 Universal Clamp Coupling

JCM 102 Extended Range Universal Clamp Coupling

JCM 171 Removable Lug Universal Clamp Coupling

JCM 172 Removable Lug Extended Range Universal Clamp Coupling

JCM 131 All Stainless Steel Universal Clamp Coupling

JCM 132 All Stainless Steel Extended Range Universal Clamp Coupling

JCM 161 Fabricated Lug All Stainless Steel Universal Clamp Coupling

JCM 162 Fabricated Lug Extended Range Universal Clamp Coupling

Optional Gaskets to accommodate line content

Buna-N, EPDM, Hypalon and Viton





HDPE
MUNICIPAL
ADVISORY
BOARD



Overview - JCM Bolted Couplings

JCM recommends the featured models for use on HDPE Pipe With Stiffeners

JCM 201 Steel Coupling

JCM 210 Series Ductile Iron Coupling

JCM 241 Optimum Range Coupling

JCM 242 Optimum Range Coupling

JCM 230 Stainless Steel Stiffeners

JCM 301 Flanged Coupling Adapter

JCM 303 Fabricated Flanged Coupling Adapter

JCM 304 Reducing Flanged Coupling Adapter

JCM 800 Spools





HDPE
MUNICIPAL
ADVISORY
BOARD



Overview - JCM Service Saddles

JCM Service Saddles provide a dependable and economical process for making taps 1/2" - 2-1/2" in Polyethylene Pipe. JCM Saddles are designed for maximum safety and performance, especially on HDPE.

JCM recommends using the Models 404 and 406 for service taps on HDPE. The wide stainless steel straps spread the load of the bolt torque across larger section of pipe, prevents point loading and supports the pipe wall around the tap area.

Sizes 4" – 24"





HDPE
MUNICIPAL
ADVISORY
BOARD



Overview - JCM Tapping Sleeves

JCM Tapping Sleeves are provided in a variety of materials to best serve the soil/environmental conditions of the pipeline.

Selection of materials and design also accommodate current municipal specifications and requirements.

Available fabricated of Carbon Steel, 304 Stainless Steel and 316 Stainless Steel, JCM has the tapping sleeve for the application.

Flanged Outlets, Mechanical Joint Outlets, Threaded Outlets, Line Stop Fittings, Mechanical Joint Tapping Sleeves





HDPE
MUNICIPAL
ADVISORY
BOARD



Overview - JCM Sur-Grip Restrainers

JCM 610 Sur-Grip Fitting Restrainer

JCM 610 Sur-Grip Joint Restrainers

JCM 610 Sur-Grip Fabricated Restrainers (14" and larger)

JCM 621 Sur-Grip Fabricated Joint Restrainer (14" and larger)

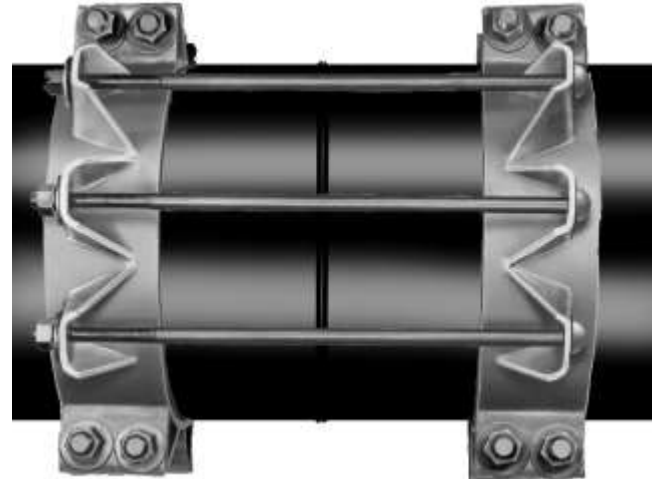



HDPE
MUNICIPAL
ADVISORY
BOARD



e & f) Products' Pressure Classes & PE4710

JCM products for HDPE are designed for underground pressurized fluid service and are pressure rated to match the pipe SDR pressure rating or with a maximum service rating of 150 PSI (Temperature 35° - 75°F / Maximum test pressure limited to rated pipe pressure or fitting, whichever is lower). Higher ratings are available and are dependent upon the specific application, contact our Engineered and Technical Sales to collaborate on the application/product parameters.

Products are not fully restrained. Restraint devices are available.

g) All Products are resistant to axial pullout:

Products are not provided restrained. Restraint devices are available per application.

For example: Joint Repair, End Caps = restrainers, tie rods
JCM Products can be provided with restraint fixtures. JCM does recommend restraint to prevent axial movement/pull out.



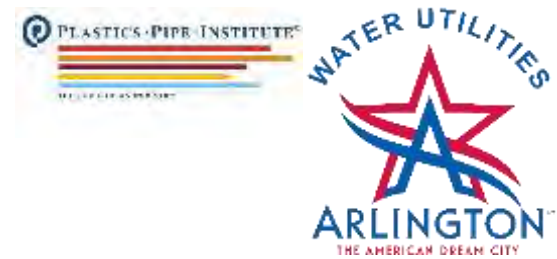

h) Available sizes, including IPS and DIPS focus on 4” – 12” HDPE sizes

Products are available for both IPS and DIPS Pipe sizes on 4” through 24” and larger.

i) Are products universal for use on other materials?

Yes – Products are cross applicable to other types of pipe with the same outside diameter.

When JCM knows it's HDPE (specifically tapping sleeves) – depending upon the application, a fabricated fitting range may be adjusted slightly downward to accommodate pipe tolerances.



HDPE
MUNICIPAL
ADVISORY
BOARD



j) Do you require modification or special installation for use on HDPE pipe?

Page Three of the JCM High Density Polyethylene Pipe Manual

General Application Information

- HDPE will relax (“creep”) at lower stress levels than other piping materials. Due to these special characteristics, the following parameters should be adhered to when utilizing JCM products for HDPE (ANSI/AWWA C901, C906).
- HDPE and bolt-on fitting connections are vulnerable to forces experienced with expansion/contraction of the pipe and require special consideration. **Restraint must be considered when joining plain end pipe to ensure against pipe pull out.** HDPE is manufactured with a smooth pipe wall surface resulting in a low coefficient of friction that can enable fittings to slide, shift, move, rotate and/or travel on the pipe after installation. JCM products are limited in the tolerance of axial movement of the pipe.
- JCM products for HDPE are designed for **underground pressurized fluid service** and are pressure rated to match the pipe SDR pressure rating or with a maximum service rating of 150 PSI (Temperature 35° - 75°F / Maximum test pressure limited to rated pipe pressure or fitting, whichever is lower). **For above ground applications, contact JCM Industries Technical Services.**
- **Pipe stiffeners must be used when joining, or connecting to HDPE.** Pipe systems must be engineered to prevent movement causing fittings to slide or rotate on the pipe. Cutting HDPE can cause the pipe to ovate or “neck” down and become egg shaped. This pipe movement can interfere with the assembly of bolt on fittings. Over time HDPE will neck down under couplings that are installed without a pipe stiffener.

Various products have specific bolt torques that reference HDPE

JCM **highly recommends pipe stiffeners/inserts** for pipe joining/connection applications with bolted fittings.

k) Do you require a maximum HDPE DR?

JCM recognizes that most common potable water pressure applications utilize HDPE SDR 17 through 9. We have found that larger pipe sizes can use higher DRs because of a thicker absolute wall thickness. For thinner wall pipe, we recommend that the user contact us to discuss the application, pressure ratings and other job specific information.





I) Ongoing work to make gasket compliant with new AWWA requirements regarding disinfectants.

JCM provides options for gasket materials for line contents and disinfectants. We offer Buna N, EPDM, Hypalon, Viton, etc.





m) Large diameter hot tapping: solutions with 4” to 8”; tapping equipment used?
Any special tooling the local water company may not have?

Tapping HDPE pipe 4” – 12” - JCM provides a full line of tapping sleeves & line stopping sleeves for HDPE - fabricated of carbon steel, 304 stainless steel and 316 stainless steel. **JCM tapping sleeves are available with specific ranges for HDPE to accommodate the thermal contraction/expansion characteristics of the pipe. JCM recommends the use of a cutter that takes larger chips rather than a saw tooth cutter.**

Concerns include: HDPE with an SDR number greater than 17 (SDR 19, 21, 26, 32.5) have a lesser wall thickness and can be subject to flexing.

Factors to be considered should be:

- wall thickness of the pipe
- travel distance of the tapping machine
- size of the tapping machine cutter

In some instances a size on size branch with a full opening may not be possible due to the wall thickness and the inability of the cutter to make a clean cut through the “shoulder” of the pipe wall. This can be addressed by simply reducing the size of the cutter (also reduces size of the cut opening). For size on size taps, JCM recommends that a cutter be two sizes smaller than the pipe diameter.

JCM recommends that no more than 90% of the I.D. be removed (compromises pipe hoop strength at outlet area).



2. Design Features that makes products compatible with properties of HDPE:

JCM addresses this in great detail in our HDPE manual – but in respect to the time provided the short answer is: **Hoop Strength, Gasket and Stored Energy.**



1. JCM Fittings are constructed with heavy duty materials: Lugs, Bolts, Stainless Steel gauge and plate – to provide the hoop strength to compress the gasket, hold the fitting in place – and support the pipe. (Fittings re-rounds and holds pipe round).
2. JCM products used a thick gasket profile with a durometer that allows the working characteristics of HDPE to fluctuate through its thermal dynamics.
3. The gaskets used are pliable enough to accommodate compression and “storage of energy” with thermal changes in the pipe, yet hard enough to stand high working pressures. As the pipe expands, the gasket compresses and stores that energy – when the pipe contracts, the gasket expands and releases the energy – this concept is what allows the watertight gasket to pipe contact to be maintained.



Success in these products is largely due to the design criteria that took the working characteristics of HDPE Pipe into consideration. Design characteristics inherent to JCM clamps, couplings, tapping sleeves, saddles and other products are as follows:

GASKETS - Tapping sleeve and service saddle gaskets should have **wide cross section** with enough volume to store compression energy. Gaskets should be of a hardness which will flex with pipe pressure fluctuations. Outlet seals should have a mechanical sealing lip that utilizes line pressure to increase seal. Outlet gaskets should be externally and internally confined.

TAPPING SLEEVE OR CLAMP BODY - Tapping sleeve or clamp coupling body should conform to the HDPE pipe and support it and the branch (in cases of outlets). Width of sleeve should be such that it spreads the load to prevent point loading or deformation of the pipe.

BOLTING - Bolts and bolting should be replaceable, self-aligning and heavy enough to properly load the gasket and assure an adequate safety factor.

Bolting/Torque Critical to applications – products design and fabricated to get as close as possible to 2% compression of the pipe – significantly reduces creep factor.

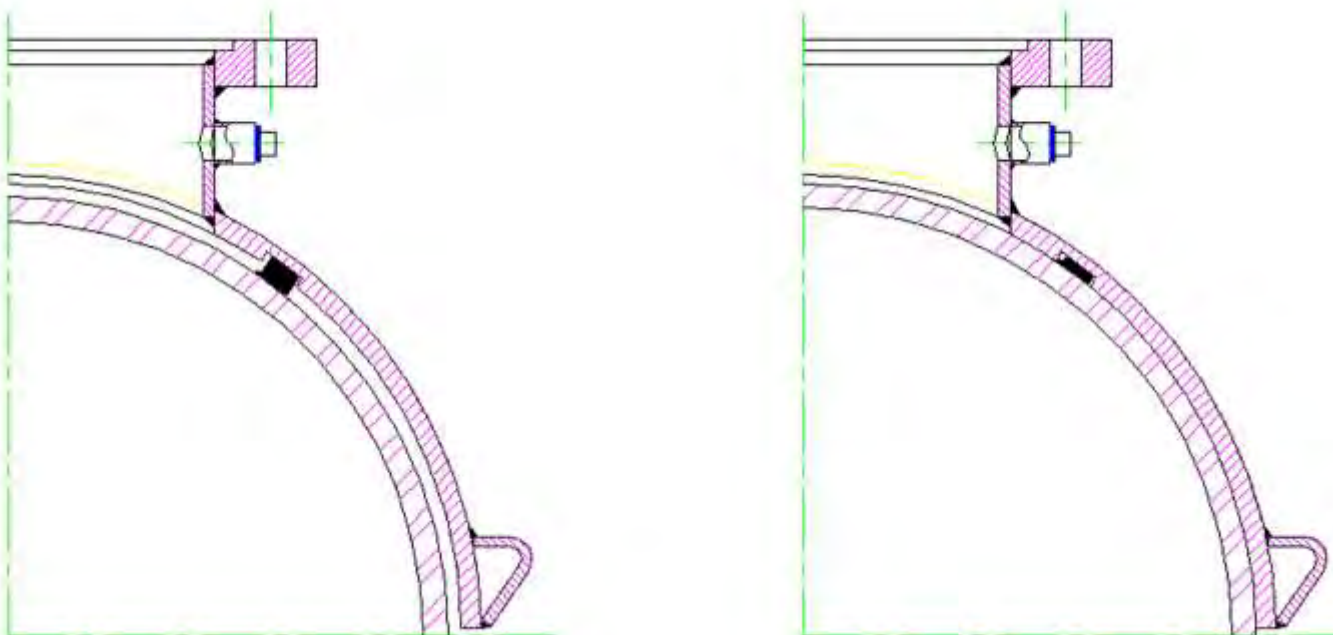

What is Unique about JCM gaskets performance on HDPE?

JCM gasket design was conceived based on the working characteristics of HDPE and the distinctive fluctuations that transform the pipe through thermal dynamics. Within the JCM Tapping Sleeves and Service Saddles, the gasket durometer (hardness of the gasket material) formulation is pliable enough to accommodate compression and storage of energy with thermal changes in pipe diameter, yet hard enough to withstand high working pressures – the working features of the gasket durometer, the broad, hydromechanical lip design and the confinement in a recessed groove around the outlet join together to provide a secure, active watertight seal at the pipe/gasket interface. The drawing above demonstrates the system of the gasket storing and releasing energy as the pipe contracts and expands.



HDPE
MUNICIPAL
ADVISORY
BOARD



JCM 454-6300 x 20 Tapping Sleeves for HDPE SDR32.5 (64 psi)





HDPE
MUNICIPAL
ADVISORY
BOARD

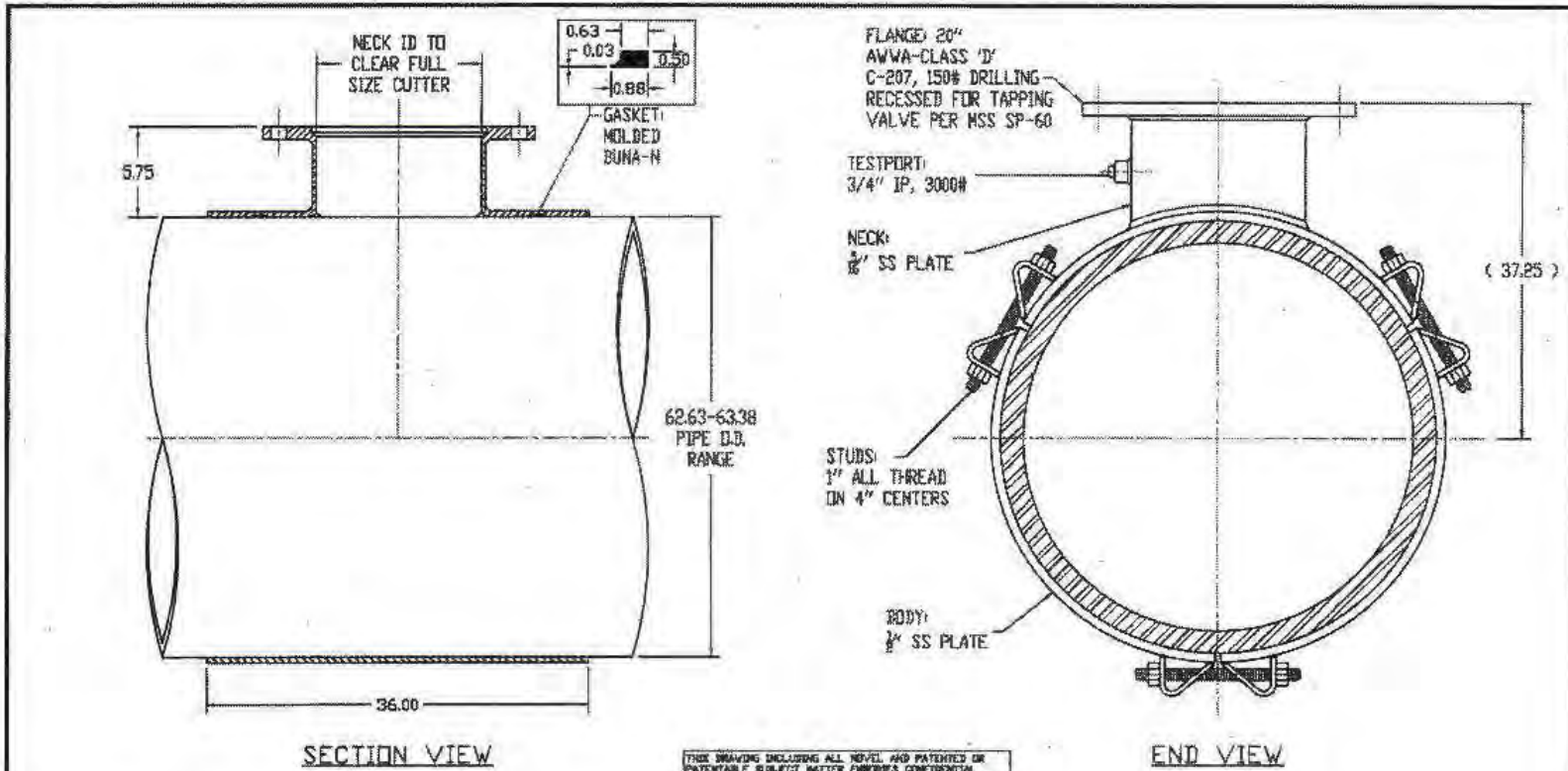

- NOTE:
- 1) ALL WELDS PER AWWA STDS.
 - 2) WORKING PRESSURE: 150 PSI
 - 3) MATERIAL - BODY: 304SS
FLANGE: CARBON STEEL
 - 4) FINISH - BODY: FULLY PASSIVATED
FLANGE: EPOXY COAT
 - 5) FASTENERS: 304 SS

THIS DRAWING INCLUDING ALL NEVEL AND PATENTED OR PATENTABLE SUBJECT MATTER CONVEYS CONFIDENTIAL INFORMATION OF JCM INDUSTRIES, INC. AND IS LOANED WITH THE UNDERSTANDING THAT IT WILL NOT BE REPRODUCED OR BE USED FOR ANY PURPOSE EXCEPT FOR WHICH LOANED UNLESS WRITTEN PERMISSION IS GRANTED BY THE OWNER AND THAT IT SHALL BE RETURNED UPON DEMAND.

				JCM		464-6300 x 20			
				JCM INDUSTRIES, INC. NASH, TX		FLANGED TAPPING SLEEVE (3-PIECE BODY)			
REV	DATE	BY	APPROV	DESIGNED BY	CHECKED BY	DATE	NO. SHEETS	TITLE NO.	REV.
				PIR		04/27/15	1 of 1	GEN-011635	

3. Testing done with HDPE pipe (tensile/restraint, pressure, cyclic, others).

1993 – working in conjunction with the HDPE pipe manufacturers (provided test pipe). JCM obtained the services of a professional tapping contractor to “tap” the test pipe under pressure and record the results experienced during the tapping process.





HDPE
MUNICIPAL
ADVISORY
BOARD

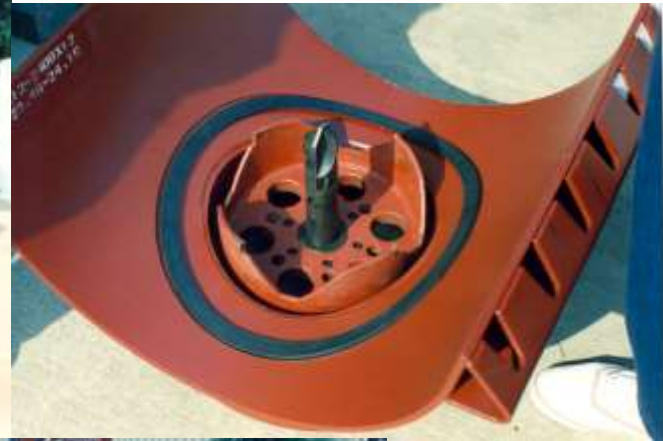



HDPE
MUNICIPAL
ADVISORY
BOARD



These tests in 1993 - put JCM fabricated tapping sleeves through 1,000 hrs. of cyclic tests.

These tests were performed in June – in Northeast Texas and remained under pressure - exposed to the elements and the ambient temperature fluctuations to test the thermal expansion/contraction to the extremes. Note the variety of sizes.

JCM recorded test process on Seven Day Dixon recorders.

Sleeves performed as expected with no leaks or failures.



Test pressures were successfully maintained and the pipe is obviously experiencing acute expansion beyond the fabricated sleeve.





HDPE
MUNICIPAL
ADVISORY
BOARD





HDPE
MUNICIPAL
ADVISORY
BOARD

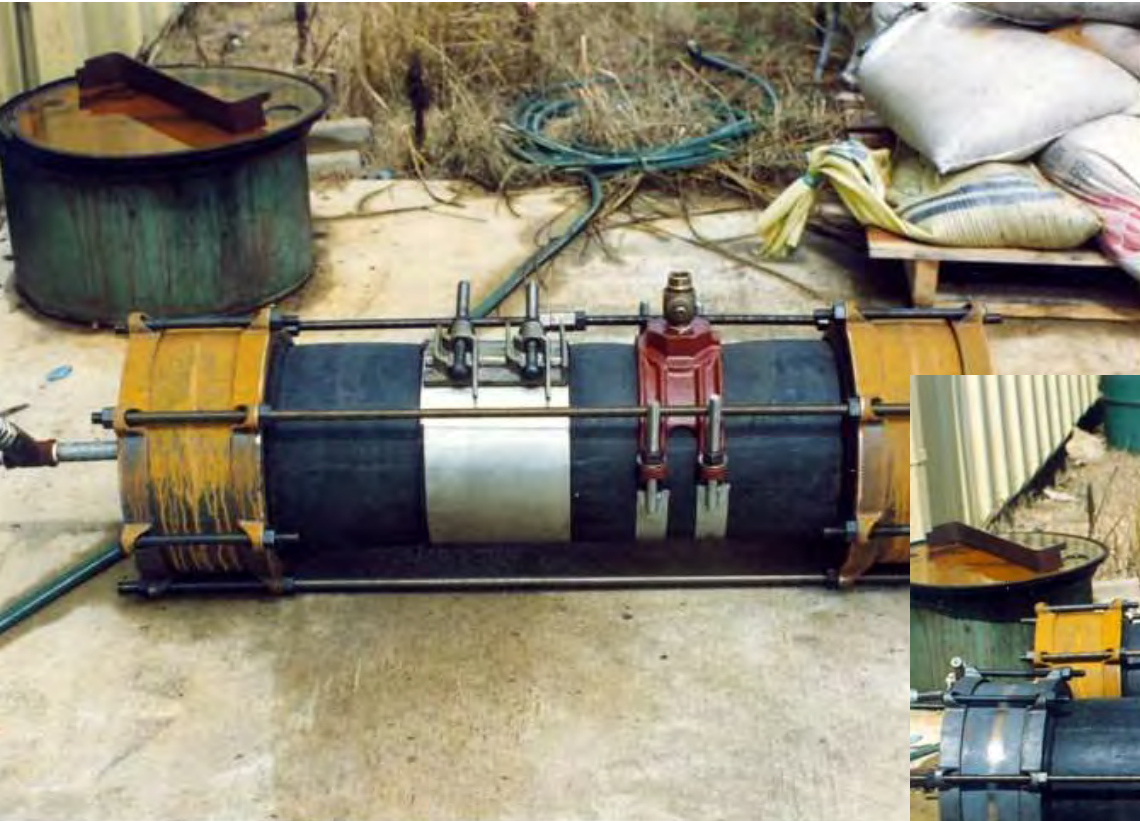



HDPE
MUNICIPAL
ADVISORY
BOARD



4. Installation Recommendations (stiffener, bolt torque, spring washers, special tooling, etc.)

- ✓ JCM **does recommend stiffener inserts & restraint** in joining/connection applications
- ✓ JCM **does recommend** meeting & confirming with **torque wrench**, the required torque levels for each product per the installation instructions
- ✓ JCM **does not use or recommend “spring” (Belleville) washers**

5. Manufacturing Standards

- ✓ JCM products are manufactured to meet or exceed the ANSI/AWWA Standards as applicable to that product. For installation procedures, see JCM HDPE Manual.

6. Projected Design Life

- ✓ JCM Products are designed the last the life of the pipeline.
- ✓ Can be Temporary or Permanent – depends upon the application
- ✓ Corrosion Protection methods – Provide fittings of ductile iron, carbon steel, 304 stainless steel, 316 stainless steel – standard paint coatings, epoxy coatings and other specialty coatings as required by the project.

7. History of use with HDPE / Case Studies / Operating Conditions

JCM has provided fittings for all types of applications on HDPE – from universal clamp couplings for simple repairs to fabricated repair sleeves for field damage and line stop fittings for major municipalities.



2013 Chalmette, LA

Line Stop Application HDPE SDR17 DIPS JCM 440-**30x24** - H₂O/45 PSI – All stainless Steel.

(9) stops performed on HDPE after flooding in New Orleans-residential and business districts in jeopardy



HDPE
MUNICIPAL
ADVISORY
BOARD



Two Unique Applications/Field Case Studies happened in Charleston, SC

PROBLEM:

Sullivan's Island,
Charleston, South Carolina

24" IPS sized High Density
Polyethylene Pipe Fusion Joint
Leaking, Underwater (saltwater) - depth
of pipeline approximately 24' – 26'.

70 PSI Working Pressure, Water

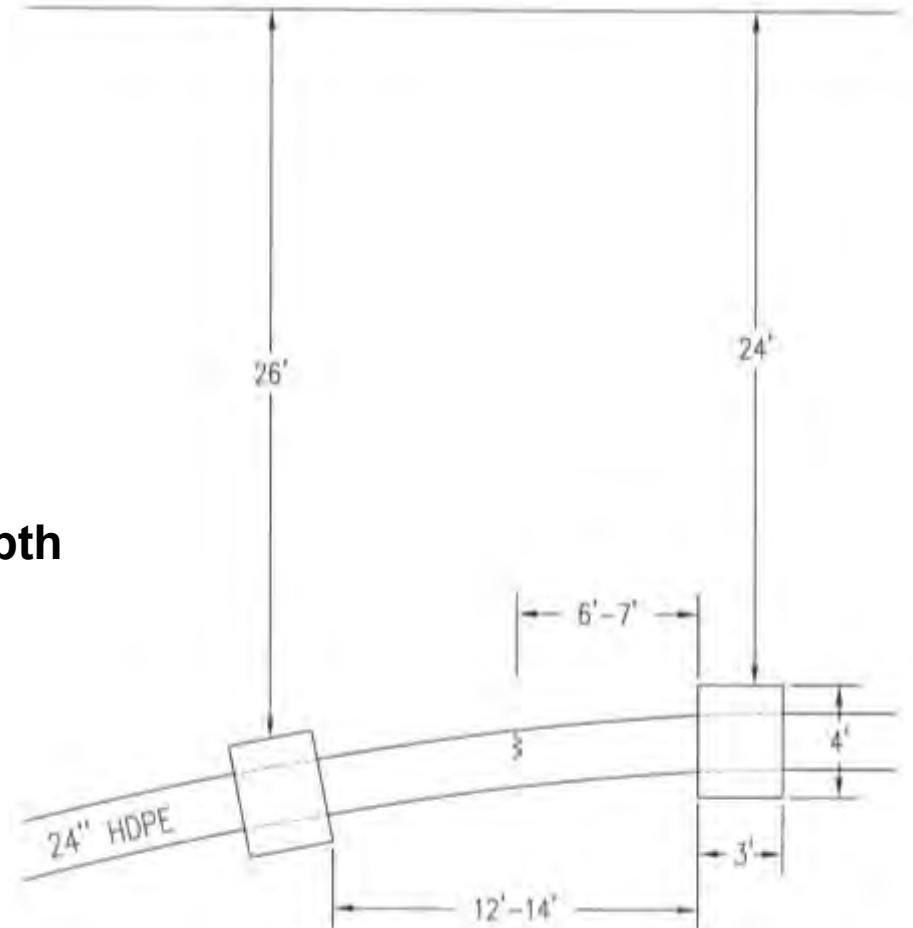



HDPE
MUNICIPAL
ADVISORY
BOARD

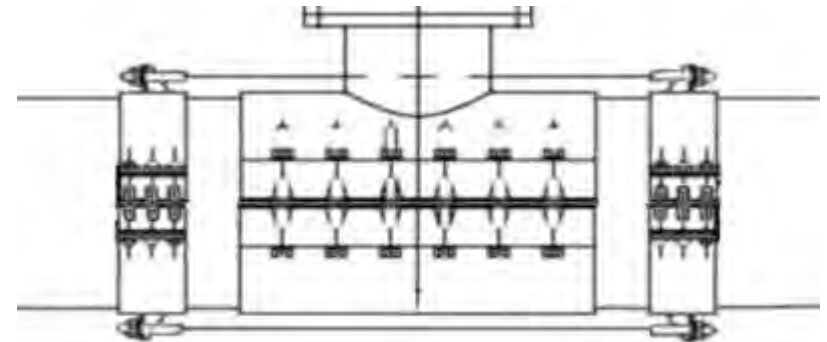
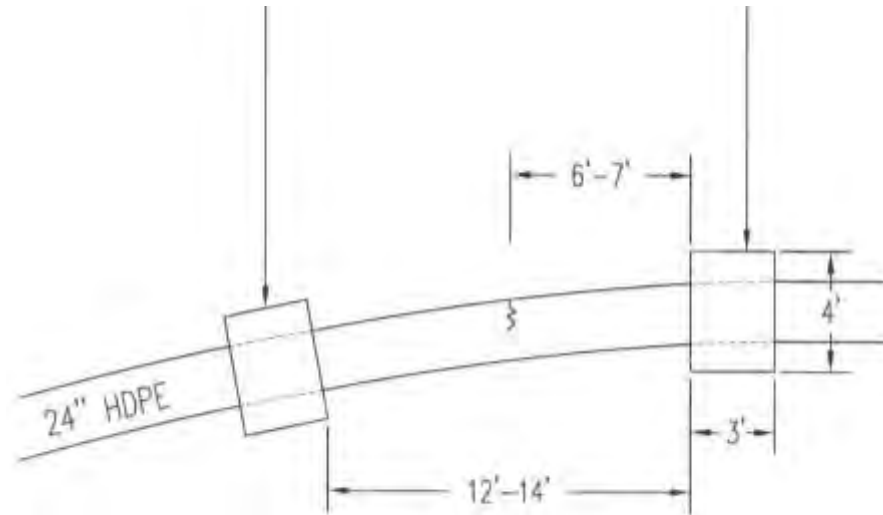

TEMPORARY SOLUTION:

As a temporary repair, Charleston Public Works used a JCM 432 Tapping Sleeve as a repair fitting and JCM 610 Restrainers to prevent further damage and movement of the pipe. (In stock at distributor location). Issues with temp repair – 304 stainless steel and carbon steel in saltwater environment.

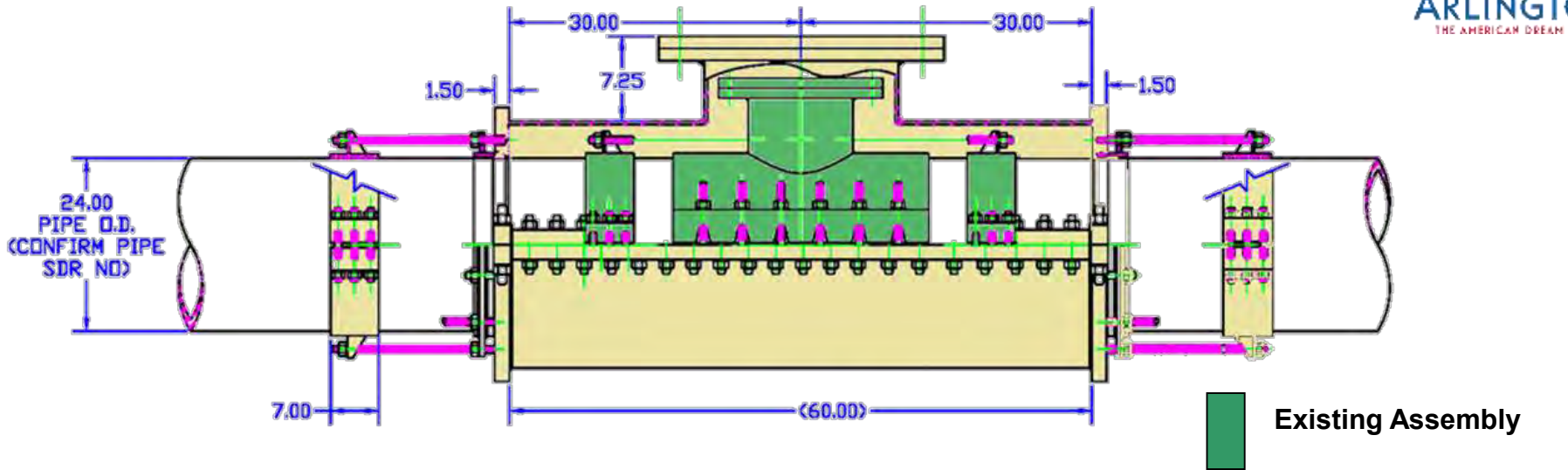

Through consultation with Charleston Public Works and JCM Industries Technical Services, it was evident that the temporary repair assembly should remain in place to prevent any additional damage to the fused joint area. The permanent repair fitting would be engineered to encapsulate the installed tapping sleeve and restrainers.

It was determined that the JCM 114 Mechanical Joint Repair Sleeve was the most suitable permanent repair fitting. The fitting would be restrained; **constructed of 316L stainless steel material** with 316L stainless hardware for installation underwater in saltwater environment; gaskets are EPDM material (chloramine application).



HDPE
MUNICIPAL
ADVISORY
BOARD



Fitting on jobsite – scrap piece of pipe for the dive technicians to do mock installation in preparation for actual install.





HDPE
MUNICIPAL
ADVISORY
BOARD



Fitting on jobsite – scrap piece of pipe for the dive technicians to do mock installation in preparation for actual install.





HDPE
MUNICIPAL
ADVISORY
BOARD



Here the top half is being hoisted for positioning. Note the “Tool Box” the technicians have added to the sleeve. This kept the necessary hand tools in a central location during the installation.





HDPE
MUNICIPAL
ADVISORY
BOARD



Bottom half of repair clamp being lowered into position.



HDPE
MUNICIPAL
ADVISORY
BOARD



Retaining Ring

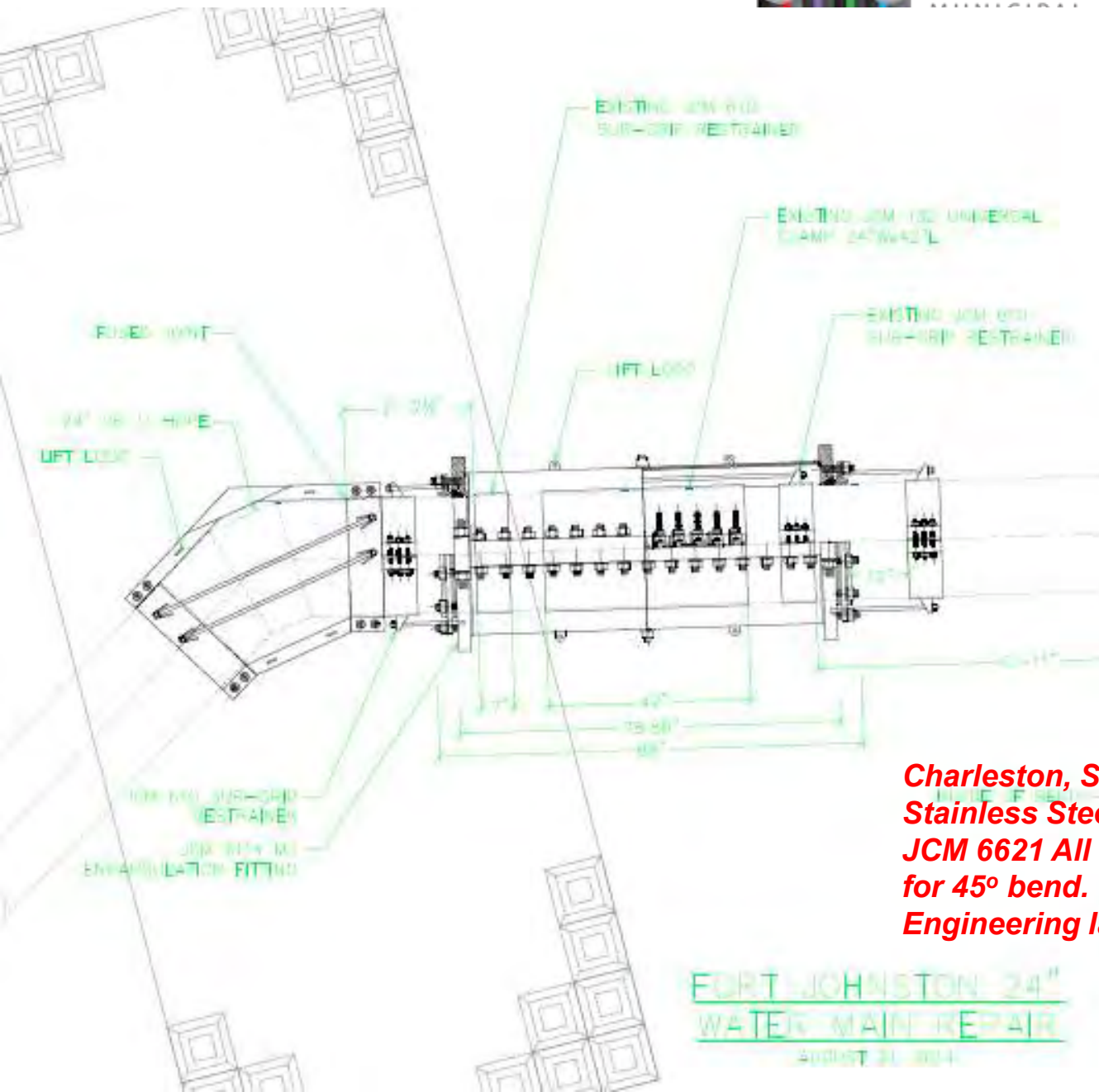

PROBLEM:
 Fort Johnson
 Charleston, South Carolina

24" SDR 11 sized High Density Polyethylene Pipe Fusion Joint Leaking, Underwater - depth of pipeline approximately 18' - 24'

100 PSI Working Pressure, Water

**Charleston, SC JCM 6114 MJ All 316 Stainless Steel Repair Sleeve
 JCM 6621 All 316 Custom Built Restrainers for 45° bend.
 Engineering layout of the final installation.**

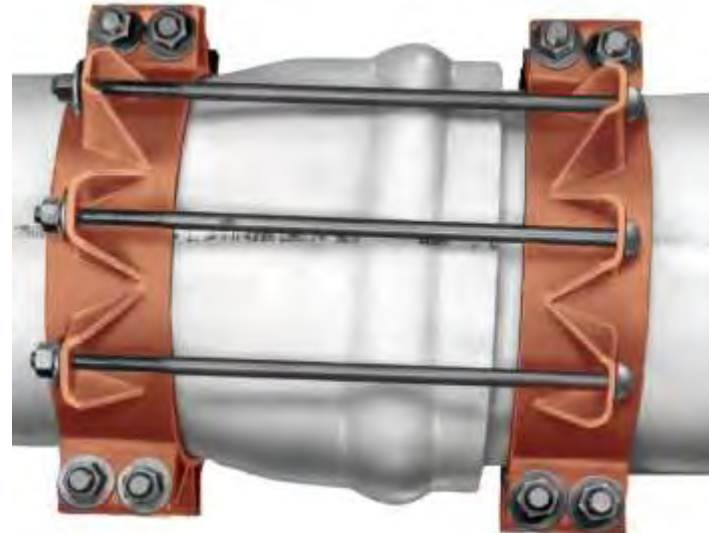

Fort Johnson - Charleston, South Carolina

As a temporary repair, a JCM 132 All (304) Stainless Steel Clamp 24" nominal size x 42" wide and JCM 610 Fabricated Restrainers (carbon steel) over the repair fitting to stabilize the pipe and prevent further damage due to pipe movement.

Also required method of stabilizing the 45° bend next to the repair site.



HDPE
MUNICIPAL
ADVISORY
BOARD



JCM fabricated another 316 stainless steel repair encapsulation sleeve. Along with 316 stainless steel restrainers.





HDPE
MUNICIPAL
ADVISORY
BOARD

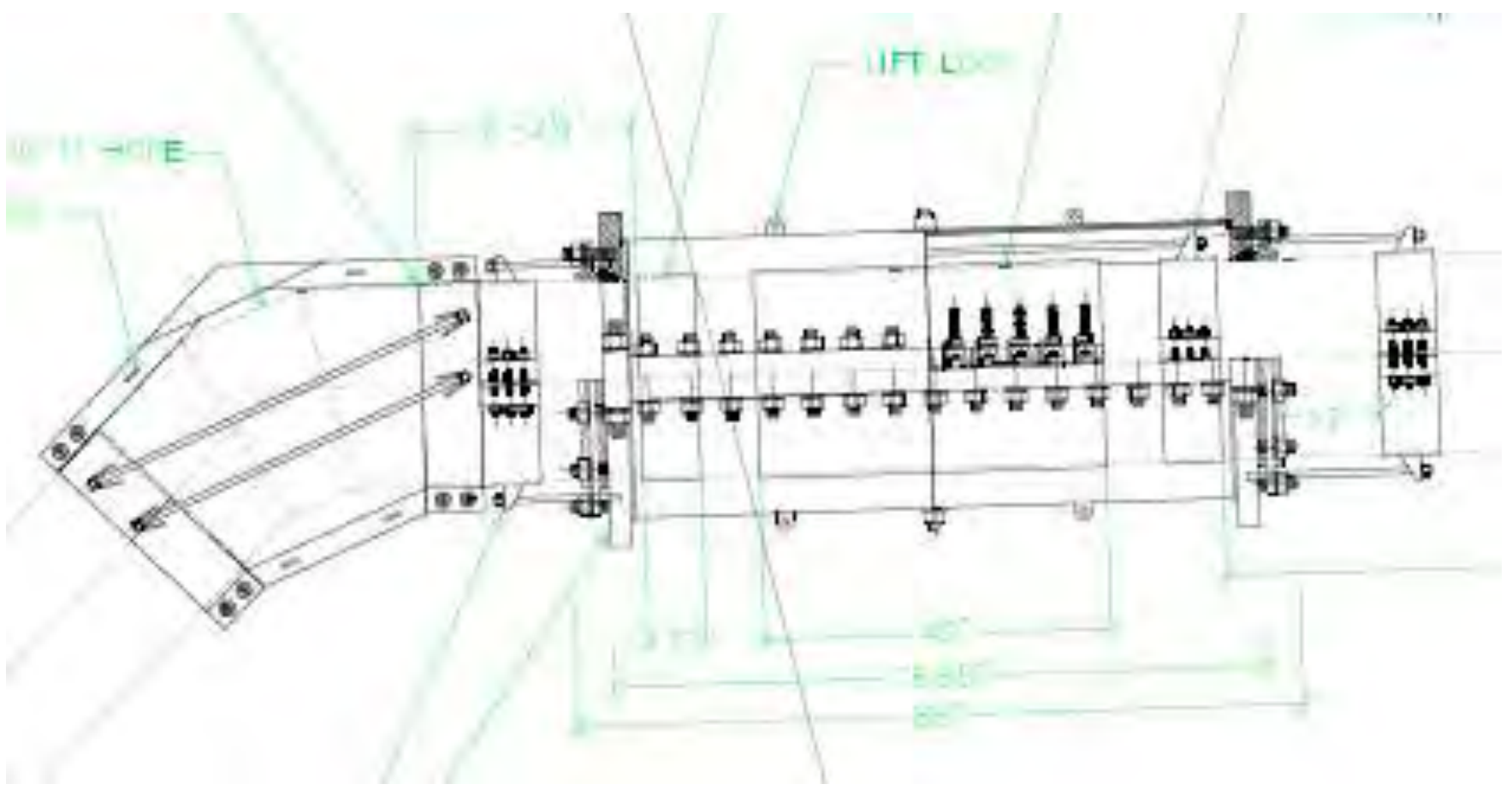



HDPE
MUNICIPAL
ADVISORY
BOARD



In addition – JCM provided Restrainers for 45° bend. Restrainers to be installed with restraint bars “stacked” with lug bolt units as shown at left.

Additional restrainer rods are inserted through ears of restrainers as shown below.



© JCM Industries, Inc.

JCM

INSTALLATION INSTRUCTIONS JCM 6621 SUR-GRIP FABRICATED JOINT RESTRAINER OF ALL 316 STAINLESS STEEL CHARLESTON, SC

1. Install the top set of restrainer ring halves on each side of the 45° degree bend/elbow. The restrainer halves should be turned so that the "hollow" sides of the restrainer "ears" face each other/the center of the unit. See figure 3.
2. Install one set (1 long, 1 short) of the restrainer bars (long=outside bar with 45° bend and short=bar with 2 slight bends) on each side of the pipe resting the bar on the top of the restrainer clamping/bolting lug. See image 1
3. Drop in bolts from top to align restrainer top and the restrainer bar. See image 1. Repeat on other side of pipe.
4. Introduce back set of restrainer ring halves, align lug/bolt holes of bottom restrainers to top set, install the bottom set of restrainers and the second set of restrainer bars. See image 1. Repeat on other side of pipe.
5. Tighten restrainer clamping bolts to minimum of 100 ft/lbs. or until metal bound. Wait a few minutes and re-torque bolts again. See Figure 2.
6. Insert long all thread restrainer rod, through top ear of one side of the elbow, across the elbow and through the ears of the other restrainer. Place washer and nut on thread to hold in place.
7. Insert second rod on top and repeat with both rods on back.
8. Place a washer and nut on end(s) of restraining all thread rods and hand tighten. Then tighten to 15 Ft. Lbs. of torque. Install second (locking) nut on rods, behind first nut, and lock into place, tighten to 15 Ft. Lbs. of torque.



Image 1

Image 2



Image 3



© JCM Industries, Inc.



HDPE
MUNICIPAL
ADVISORY
BOARD





HDPE
MUNICIPAL
ADVISORY
BOARD





The information included in this program is based on the most recent available in the piping industry. It is presented for the viewers use and education. Information provided should not considered formal recommendations for product application.

For specific product recommendation, end user should provide application information, including pipe size, SDR number, working pressure, and specific information as to application (i.e. repair, connection, branching).

JCM Industries invites inquiries concerning the application of our products. Viewers may contact us at:

800-527-8482 or 903-832-2581

www.jcmindustries.com



Mechanical Tapping Sleeve 8" HDPE Pipe City of Duluth, MN

JCM Model 452 Tapping Sleeve

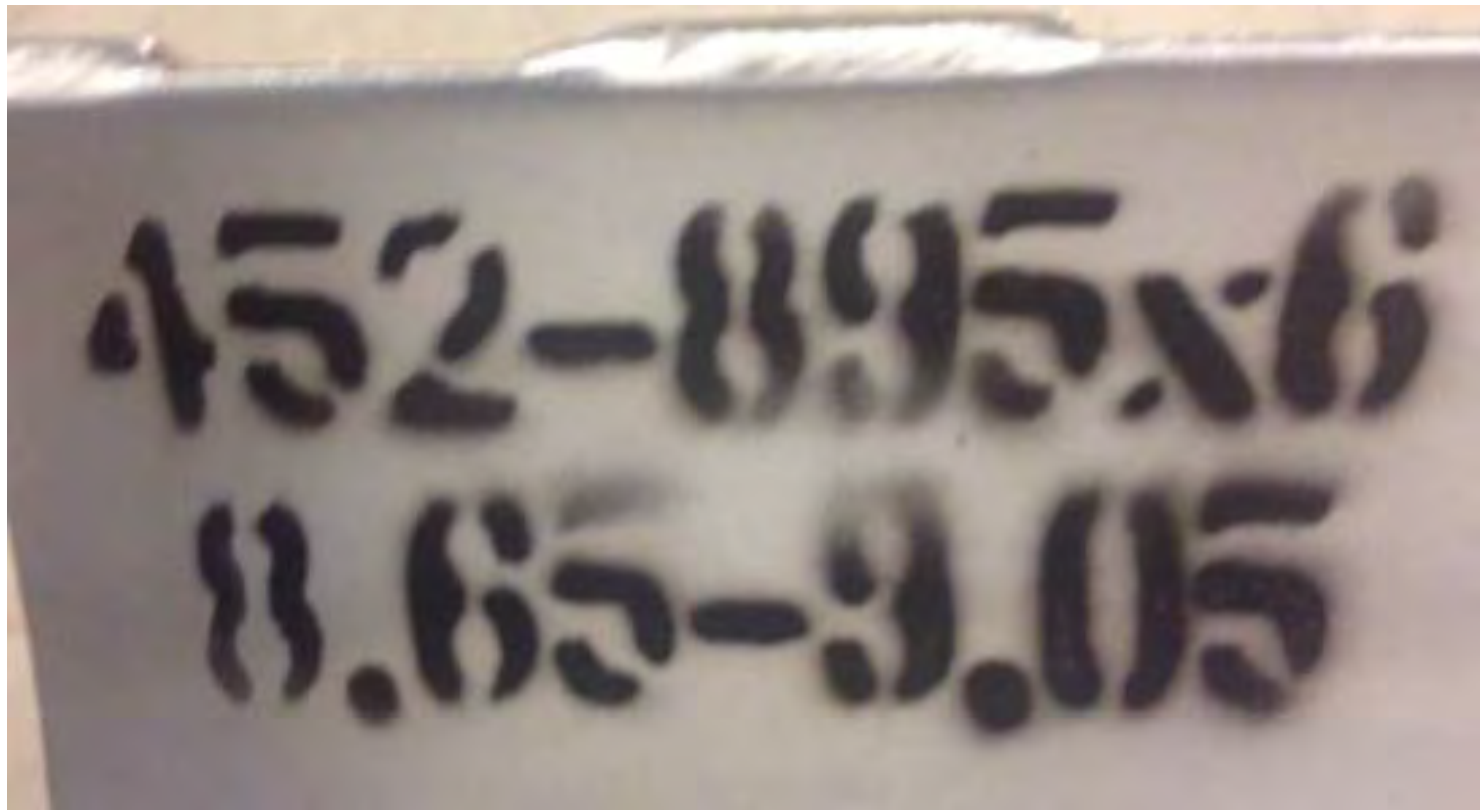



HDPE
MUNICIPAL
ADVISORY
BOARD





HDPE
MUNICIPAL
ADVISORY
BOARD



- Installed sleeve on pipe but did not tap
- Bolts torqued to 80 ft-lbs
- Pressurized 6 inch branch
- **NO WATER IN PIPE**







HDPE
MUNICIPAL
ADVISORY
BOARD



- Initial test pressure – 52 psi
- Room temperature of 68 degrees F
- Left inside multiple days
- no pressure change
- no visible leakage



Moved outside for multiple days

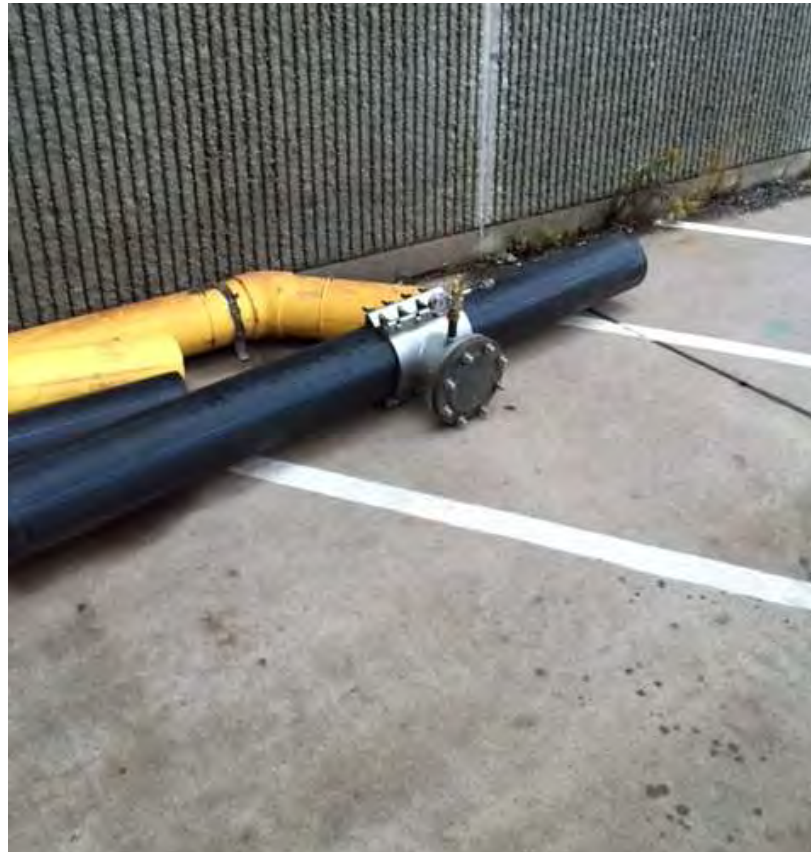



HDPE
MUNICIPAL
ADVISORY
BOARD



- Outside temperature – 32 to 35 degrees F
- Pressure – 38 psi
- Pressure drop -14 psi
- No visible leakage
- Pressure rebound when pipe taken back inside





Conclusions – Test 1

- Pressure drop due to contraction of water caused by temperature drop
- No leakage present

Test 2

- Tapped branch
- Capped ends
- Pressurized entire system



HDPE
MUNICIPAL
ADVISORY
BOARD





HDPE
MUNICIPAL
ADVISORY
BOARD



- Initial test pressure – about 80 psi
- Room temperature of 68 degrees F
- Left inside multiple days
- no pressure change
- no visible leakage





HDPE
MUNICIPAL
ADVISORY
BOARD



- Outside temperature – 32 to 35 degrees F
- Pressure – 111 psi
- Pressure increase - 31 psi
- No visible leakage
- Pressure decrease when pipe taken back inside





Conclusions – Test 2

- Pressure increase due to contraction of the HDPE pipe
- No leakage present

Hot Tap





HDPE
MUNICIPAL
ADVISORY
BOARD



Pressurized to 80 psi





HDPE
MUNICIPAL
ADVISORY
BOARD



Hot tap



Observations



Debris after disassembly



Observations



HDPE
MUNICIPAL
ADVISORY
BOARD



Fit on the pipe is NOT tight at outer edges



Observations



HDPE
MUNICIPAL
ADVISORY
BOARD



Fit on the pipe is NOT tight at outer edges



Observations



HDPE
MUNICIPAL
ADVISORY
BOARD



Pipe is deformed at sleeve



Observations



Pipe is deformed at sleeve



Observations



Pipe is deformed at sleeve





Conclusions

- Pipe did not leak in temperatures varying from 68 degrees F to 33 degrees F
- Deformation of the main can be expected.
- Deformation did not appear to affect performance