

Designing PEX Plumbing Systems to Optimize Performance and Efficiency

A presentation by the Plastics Pipe Institute



Contact

Lance MacNevin, P.Eng.

PPI Director of Engineering - Building & Construction Division

Imacnevin@plasticpipe.org Tel (469) 499-1057

The Plastics Pipe Institute

PPI Represents All Sectors of the Plastic Pipe Industry

- PPI was formed in 1950 to develop test methods for plastic pressure pipes
- Today: Non-profit trade association serving North America

PPI Mission: To advance the acceptance and use of plastic pipe systems through research, education, technical expertise and advocacy

Members: PPI members share a common interest in broadening awareness and creating opportunities that expand market share and extend the use of plastics pipe in all of its many applications

2020: Over 170 members firms involved with the plastic pipe industry around the world

Website: www.plasticpipe.org

The Plastics Pipe Institute

PPI Represents All Sectors of the Plastic Pipe Industry

- PPI's five divisions focus on solutions for multiple applications:
 - **Building & Construction Division (BCD)**
 - Drainage
 - Energy Piping Systems
 - Municipal & Industrial
 - Power & Communications

BCD Materials: PEX, CPVC, PE-RT, PEX-AL-PEX, PP, HDPE (Geothermal)

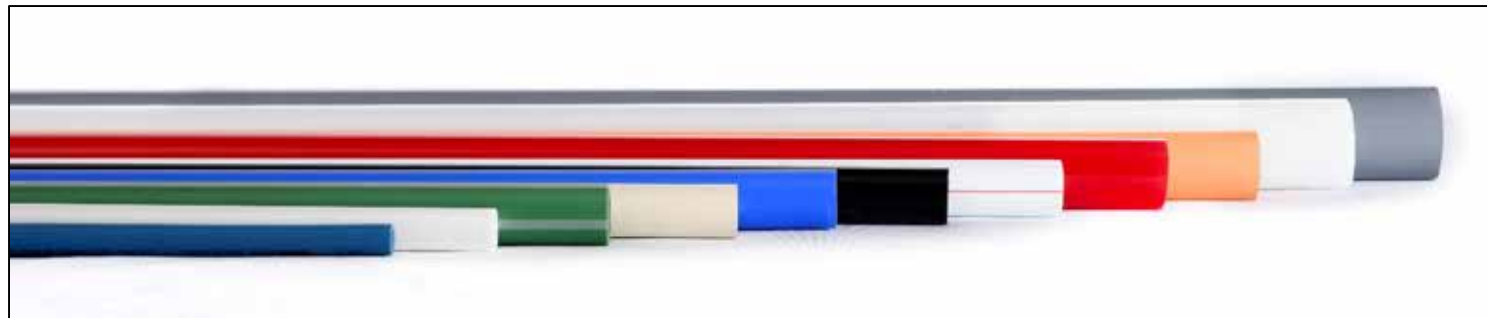

The Plastics Pipe Institute

PPI's Building & Construction Division (BCD)

BCD is focused on plastic pressure pipe and tubing systems used within buildings and on building premises for applications such as plumbing, water service, fire protection, hydronic heating and cooling, snow and ice melting, district heating and cooling, and ground source geothermal piping systems.

BCD involvement with industry groups:



Course Introduction

- PEX tubing has been used for plumbing systems in North America for over 25 years, providing safe delivery of potable water and protecting the health of building occupants
- A result of modern polymer technology, PEX tubing performs in ways that provide superior reliability, durability and safety
- PEX systems are already established for residential applications, and are being adopted for commercial plumbing applications
- This course demonstrates how the properties of PEX systems can improve the health, safety and welfare of building occupants through efficient and reliable delivery of clean water

Course Background

- Much of the information in this course is taken from the PEX Plumbing **DESIGN GUIDE**
- Both PPI and PPFA provided content to *Home Innovation Research Lab**, which also conducted the included research
- The **GUIDE** is available as free download from:
www.plasticpipe.org (BCD homepage)
www.homeinnovation.com

**Formerly known as the NAHB Research Center*

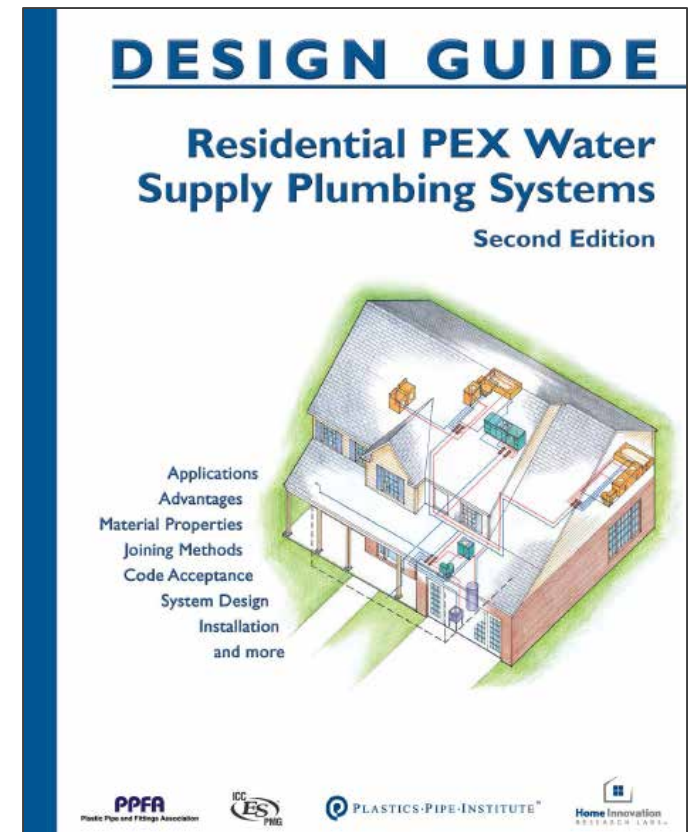

Course Background

Plastic Pressure Pipe Design Calculator

- For design calculations related to pressure loss, pipe weight/volume, thermal expansion & contraction, expansion arm/loop design and to predict hydraulic shock & pressure surges, simply go to www.plasticpipecalculator.com and hit



Plastic Pressure Pipe Design Calculator

PRESSURE DROP / HEAD LOSS

Input

Pipe/Tubing Selection

Pipe/Tubing Material:	PEX
Sizing Type (CTS/IPS/Metric):	CTS (ASTM F876/CSA B137.5)
Wall Type (SDR/Schedule):	SDR 9
Nominal Pipe/Tubing Size:	1

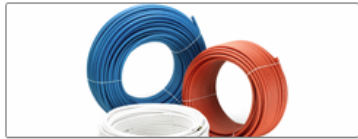

[More information on PEX](#)

Learning Objectives

By the conclusion of this course, participants should be able to:

1. Explain how the properties of PEX tubing and fittings can improve health, safety and welfare through improved plumbing materials
2. Describe three distinct plumbing layouts using PEX systems and compare advantages and disadvantages of each
3. Apply test data from published research to demonstrate how design of the plumbing layout can improve system performance and provide faster delivery of hot-water with reduced water waste
4. Direct an installer on correct installation techniques for PEX systems to ensure long-term safety and performance
5. Discuss how to access industry resources for material, design and installation info

1. How PEX Tubing and Fittings Can Improve Health, Safety and Welfare

This Learning Objective will explain the piping components:

1. PEX Tubing: Crosslinked Polyethylene
2. PEX Fittings: Brass, copper and polymer materials, several designs
3. Plumbing Distribution Manifolds: Several designs and materials
4. Tubing Fasteners: Those intended for PEX plumbing systems



How PEX Tubing and Fittings Can Improve Health, Safety and Welfare

1. PEX: Crosslinked Polyethylene

- Introduced for radiant heating in the early 1970s in Europe
- Introduced to USA and Canada in 1984 for heating and plumbing
- PEX is a high-temperature flexible pressure piping system
- PEX tubing systems are used for water service lines, hot- and cold-water distribution, radiant heating *and* cooling, outdoor snow and ice melting, residential fire protection, geothermal ground loops and other demanding applications



Courtesy Viega

How PEX Tubing and Fittings Can Improve Health, Safety and Welfare

PEX: Crosslinked Polyethylene

Formal Definition – “Crosslinked Polyethylene is a polyethylene material which has undergone a change in molecular structure using a chemical or a physical process whereby the polymer chains are chemically linked. Crosslinking of polyethylene into PEX for pipes results in improved properties such as elevated temperature strength and performance, chemical resistance, and resistance to slow crack growth.”

Source: PPI Technical Note 17

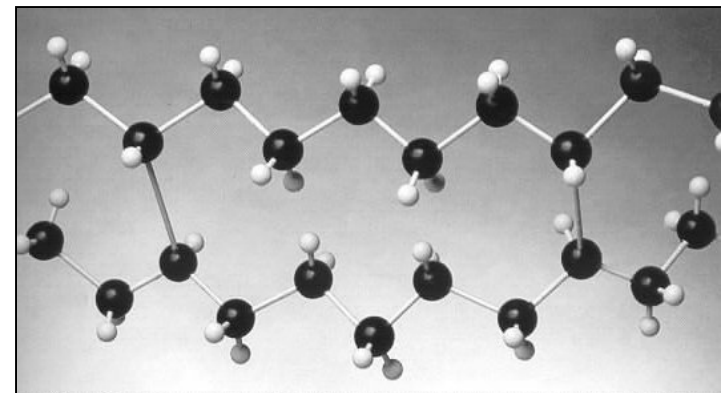

How PEX Tubing and Fittings Can Improve Health, Safety and Welfare

PEX: Crosslinked Polyethylene

- PEX plumbing tubing is currently produced in nominal tubing sizes from 1/4 to 3
- PEX is available in natural (white) or colors such as red, white, blue, black, orange
- PEX tubing is available in coils or straight lengths, depending on the customer preference and application



Courtesy BOW

How PEX Tubing and Fittings Can Improve Health, Safety and Welfare

Advantages of PEX Plumbing Systems

- Safety of potable water and long-term reliability
- Resistance to corrosion, erosion, water disinfectants
- Smooth wall, excellent flow characteristics
- High pressure capability/stability (reduced creep)
- Quiet operation, absorbs pressure surges (reduced water hammer)
- Flexibility to ease installations
- Many fitting and joining options; no open flames
- Proven long life, rigorous certifications, highly tested
- Water conservation is assisted with reduced heat loss



How PEX Tubing and Fittings Can Improve Health, Safety and Welfare

PEX Plumbing Systems are Sustainable

- Lower cost to the environment for production
- No mining operations for the ore
- Low energy cost to produce PEX as compared with copper
- Smooth wall, excellent flow characteristics reduce pumping costs
- Proven long life and durability provides value
- Light weight of PEX reduces transportation costs
- Flexibility can dampen water hammer, reducing pressure spikes
- PEX pipe does not add minerals to drinking water
- PEX systems protect health and safety



How PEX Tubing and Fittings Can Improve Health, Safety and Welfare

Proven Success

- Since 1997, the usage of PEX tubing in residential plumbing has increased from less than 10% to **more than 60%** (Source: HIRL, Aug. 2016)

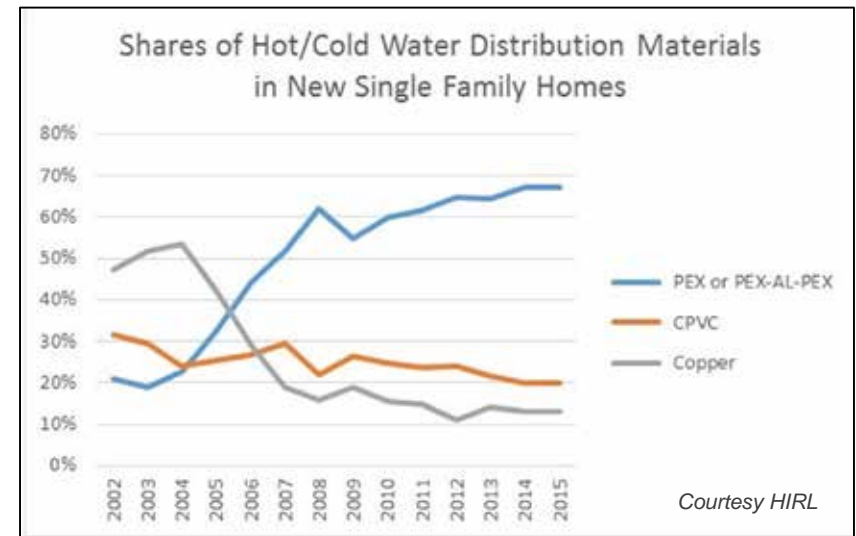

How PEX Tubing and Fittings Can Improve Health, Safety and Welfare

PEX Tubing Production Methods

The three common methods of crosslinking polyethylene are:

- **Peroxide (PEX-a)**
- **Silane (PEX-b)**
- **Electron beam (PEX-c)**

- Letter designations not related to any type of performance rating system

- PEX tubing produced by each of the three methods must meet the same technical requirements as specified in the relevant PEX standards

How PEX Tubing and Fittings Can Improve Health, Safety and Welfare

PEX Tubing Production Methods

The three common methods of crosslinking polyethylene are:

- **Peroxide (PEX-a):** *This method employs organic peroxides that generate reactive free radicals that splice PE chains together during extrusion*
- **Silane (PEX-b):** *This method involves grafting a reactive silane molecule to the backbone of the polyethylene; crosslinking reaction is completed during moisture-curing in a steam “sauna” or hot-water bath*
- **Electron beam (PEX-c):** *This method involves subjecting the extruded PE pipe to a dose of high-energy electrons*

- [See PPI Technical Note 17](#) for more details about each method

How PEX Tubing and Fittings Can Improve Health, Safety and Welfare

PEX Tubing Standards

- There are two primary standards for PEX tubing in North America:
 - **ASTM F876** *Standard Specification for Crosslinked Polyethylene (PEX) Tubing*
 - **CSA B137.5** *Crosslinked Polyethylene (PEX) Tubing Systems for Pressure Applications*
- Codes such as IPC, UPC and the NPC of Canada refer to these standards



How PEX Tubing and Fittings Can Improve Health, Safety and Welfare

PEX Tubing Standards

- ASTM F876 and CSA B137.5 establish capabilities and test requirements, such as:
 - Dimensions
 - Long-term pressure ratings
 - Quick burst pressures
 - Chlorine resistance
 - UV resistance
 - Excessive pressure-temperature capability
 - Hot-bend and cold-bend tests
 - Marking requirements
 - Even more...



How PEX Tubing and Fittings Can Improve Health, Safety and Welfare

PEX Tubing Standards: Dimensions

- PEX tubing is Nominal Tubing Size (NTS)
- All PEX tube dimensions are the same (within slight tolerances)
- PEX is **Copper Tube Size** (CTS, same OD as copper tubing)
- PEX is **SDR9** (wall thickness is 1/9 of the OD) with tight tolerances on dimensions

Example:

- 3/4 Nominal Tubing Size (NTS): Outside diameter = 0.875" +/- 0.004"
- 3/4 Nominal Tubing Size (NTS): Wall thickness = 0.097" - 0.107"
- 3/4 Nominal Tubing Size (NTS): Out-of-roundness* = ≤ 0.016 "

**measured prior to coiling*



How PEX Tubing and Fittings Can Improve Health, Safety and Welfare

PEX Tubing Standards: “Tubing vs. Pipe”

- PEX “Tubing”: the actual Outside Diameter is 1/8 inch larger than the nominal size
- PEX “Pipe”: the actual Outside Diameter matches that of steel pipe of the same nominal size, or products where the actual OD matches the nominal size
 - PEX Pipe uses nominal sizes such as ‘NPS 3/4’
 - PEX Pipe is not widely used for plumbing in NA
 - PEX Pipe is typically used in industrial applications and in larger diameters
 - ASTM F2788 applies to PEX Pipe, not intended for plumbing applications
- While people often use “Tubing” and “Pipe” interchangeably, “Tubing” is accurate

How PEX Tubing and Fittings Can Improve Health, Safety and Welfare

PEX Tubing Standards: Test Methods

- Specific test methods for PEX Tubing:
 - **ASTM F2023** *Standard Test Method for Evaluating the Oxidative Resistance of Crosslinked Polyethylene (PEX) Tubing and Systems to Chlorinated Hot Water*
 - **ASTM F2657** *Standard Test Method for Outdoor Weathering Exposure of Crosslinked Polyethylene (PEX) Tubing*



PEX Tubing is also certified to:

- **NSF/ANSI Standard 61** *Toxicological Evaluation for Materials in Contact with Drinking Water (“Health Effects”)*
- **NSF/ANSI Standard 372:** *Drinking Water System Components, Lead Content*



How PEX Tubing and Fittings Can Improve Health, Safety and Welfare

Categories for Performance – Three Key Properties:

1. Chlorine Resistance
2. UV Resistance
3. Hydrostatic Design Strength (HDS), related to pressure ratings

- Performance categories are defined in the **“Tubing Material Designation Code”**
- See example:

		 F876 – 19a				
		TABLE 1 Thermoplastic Tubing Material Designation Code Cells for SDR9 PEX				
		PEX	1	1	0	6
Material	_____↑					
Chlorine Resistance (75% at 73°F and 25% at 140°F)	_____↑					
Minimum UV Resistance (1 month)	_____↑					
HDS at 23°C (630 psi)	_____↑					

How PEX Tubing and Fittings Can Improve Health, Safety and Welfare

Chlorine Resistance: Evaluation

Details:

- All PEX intended for use with potable water must have a minimum extrapolated lifetime of **50 years** when tested in accordance with ASTM Test Method F2023
- Multiple specimens of tubing are tested to failure at three pressure and three temperatures, typically 95°C, 105°C and 115°C (203°F, 221°F and 239°F)
- “Extrapolated time-to-failure” of tubing at each end-use condition (**1, 3, 5**) is calculated using Miner’s Rule formula, based on end-use conditions of **80 psig @ 140°F**
- See **PPI TN-53 *Guide to Chlorine Resistance Ratings***... for more information

How PEX Tubing and Fittings Can Improve Health, Safety and Welfare

Chlorine Resistance: Four (4) Categories of Performance

0: Not tested or not rated

1: 25% of time hot at 140°F, 75% of time at 73°F (e.g. intermittent hot water)

3: 50% of time hot at 140°F, 50% of time at 73°F (e.g. timed hot water recirculation, such as up to 12 hours per day)

5: 100% of time hot at 140°F (e.g. continuous recirculation of hot water, no timer)

Note: 73°F = 23°C, 140°F = 60°C

Property	Standard	0	1	2	3	4	5
Chlorine Resistance	F2023	Not tested or rated	75 % at 73°F and 25 % at 140°F	Reserved	50 % at 73°F and 50 % at 140°F	Reserved	100 % at 140°F

How PEX Tubing and Fittings Can Improve Health, Safety and Welfare

UV Resistance: Evaluation

- Natural exposure is based on worst-case North American location (near Phoenix, AZ)
- Tubing samples are mounted outdoors, facing **South**
- Samples are left outdoors until the required amount of UV exposure is accumulated (e.g. 30 days, 90 days..)
- Actual UV exposure is measured daily

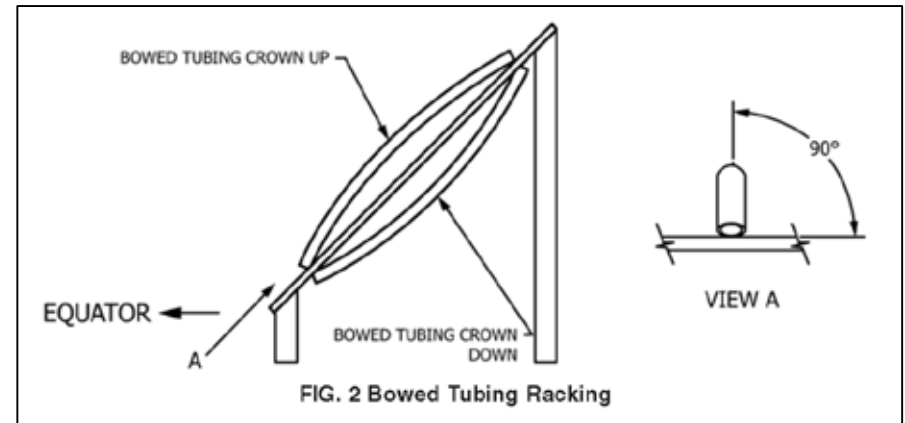

How PEX Tubing and Fittings Can Improve Health, Safety and Welfare

UV Resistance: Four (4) Categories of Performance

0 = Not tested or not rated

1 = 1 month

2 = 3 months

3 = 6 months or more Minimum UV resistance

From ASTM F876, **Table 1**

Property	Standard	0	1	2	3
Minimum UV Resistance	F2657	Not tested or rated	1 month	3 months	6 months

How PEX Tubing and Fittings Can Improve Health, Safety and Welfare

PEX Tubing Standards: Burst Pressure

- Product standards have equivalent requirements for short-term burst pressure :
- **Requirements:**
 - **ASTM F876** 475 psig at 73°F
 - **CSA B137.5** 3.27 MPa @ 23°C (the SI equivalent)
- PEX tubing and systems are also tested for burst pressure capabilities at 180°F and 200°F (82°C and 93°C)

Details:

- PEX tubing is tested in accordance with **ASTM D2837**

How PEX Tubing and Fittings Can Improve Health, Safety and Welfare

PEX Tubing Standards: Pressure Ratings

- Product standards have equivalent requirements for long-term pressure ratings:
- **Requirements:**
 - **ASTM F876** 100 psig at 180°F
 - **CSA B137.5** 690 kPa @ 82°C (the SI equivalent)
- PEX tubing and systems are also tested for sustained pressure capabilities at 73°F and 200°F (23°C and 93°C)

Details:

- PEX tubing is tested in accordance with **ASTM D2837** and listed according to *PPI TR-3 Policies and Procedures for Developing Hydrostatic Design Basis (HDB) and Hydrostatic Design Stresses (HDS) for Thermoplastic Piping Materials*

How PEX Tubing and Fittings Can Improve Health, Safety and Welfare

PEX Tubing Standards: Degree of Crosslinking

- The Minimum and Maximum Degree of Crosslinking is prescribed in product standards
- **Requirements from ASTM F876:**
 - Peroxide method, allowable range = 70% - 89%
 - Silane method, allowable range = 65% - 89%
 - Electron-beam method, allowable range = 65% - 89%

Details:

- PEX tubing is tested in accordance with **ASTM Test Method D2765 Method B**

How PEX Tubing and Fittings Can Improve Health, Safety and Welfare

PEX Tubing Standards: Flame and Smoke Ratings

- If PEX tubing is to be installed within a return air plenum that requires “non-combustible materials” then the tubing must demonstrate a flame spread rating ≤ 25 and a smoke spread rating ≤ 50
- These values are generated in standardized testing in accordance with **ASTM E84** and **CAN/ULC S102.2** test methods using the “Steiner Tunnel” test
- Image of Steiner Tunnel at UL LLC



How PEX Tubing and Fittings Can Improve Health, Safety and Welfare

PEX Tubing Standards: Flame and Smoke Ratings

- If PEX tubing is to be installed within a return air plenum that requires “non-combustible materials” then the tubing must demonstrate a flame spread rating ≤ 25 and a smoke spread rating ≤ 50
- Each PEX manufacturer submits its tubing for testing and publishes the listings
- Suggested spec language: “PEX tubing shall have a Flame Spread Index ≤ 25 and a Smoke Developed Index ≤ 50 listed to ASTM E84 (USA) or CAN/ULC S102.2 (Canada). This listing may require the tubing to be installed in a rated insulation material or an approved steel support channel.”

How PEX Tubing and Fittings Can Improve Health, Safety and Welfare

PEX Performance: Freeze Break Resistance

- PEX tubing is less susceptible to the effects of cold temperatures, retaining its flexibility even below freezing
- This flexibility means that if water-filled PEX tubing freezes, the elasticity of the material allows it to expand without cracking or splitting
 - Tube will return to its original size upon thawing
- This applies when PEX tubing has room to expand evenly along its length, as is typical when installed within walls or ceilings for plumbing applications
- Water-filled PEX tubing allowed to freeze inside a slab or highly-compacted soil may *not be able* to expand evenly, and may be damaged

- [Consult with tubing manufacturer for more information](#)

How PEX Tubing and Fittings Can Improve Health, Safety and Welfare

PEX Performance: R-Value and Conductivity

PPI TR-48: *R-Value and Thermal Conductivity of PEX and PE-RT* reports these findings:

- PEX k-value: 2.86
- Copper k-value: 196 (68 times more conductive)

Thermal Resistance of PEX

- PEX size: 1/2" 3/4" 1" 1 1/4" 1 1/2" 2"
- R-value: 0.028 0.038 0.049 0.060 0.072 0.093

Although PEX tubing has inherent insulating properties, insulation is still recommended for certain installations



How PEX Tubing and Fittings Can Improve Health, Safety and Welfare

PEX Performance Vs. Copper Tubing

- Corrosion resistance, erosion resistance (no pinholes)
- Resistance to scale and build-up
- Flexibility absorbs surge pressures, water hammer
- Quiet operation, no vibration transfer
- Tolerates high velocities
- Better heat retention, less condensation
- No flame used for joining, less burn risk
- No solder or flux added at joints
- Freeze-break resistance
- Light weight, easier to transport
- A more sustainable choice, better design options



How PEX Tubing and Fittings Can Improve Health, Safety and Welfare

2. PEX Fittings

- There are several types of fittings designed for use with PEX tubing
- PEX fittings are produced from **lead-free brass alloys, copper** and **polymers**
- **Polysulfone (PLS)** and **polyphenylsulfone (PPSU)** are thermoplastic polymers known for their toughness, stability at high temperatures, and chlorine resistance
- These are the typical polymers used for fittings and manifolds as part of PEX systems



How PEX Tubing and Fittings Can Improve Health, Safety and Welfare

PEX Fitting Standards

- **ASTM F877** *Standard Specification for Crosslinked Polyethylene (PEX) Plastic Hot- and Cold-Water Distribution Systems*
- **CSA B137.5** *Crosslinked Polyethylene (PEX) Tubing Systems for Pressure Applications*
- These standards define the performance of the joints/connections, test methods, etc.
 - Burst pressure, long-term sustained pressure
 - Hot- and cold-water thermocycling
- PEX fittings must also meet **NSF/ANSI Standard 61 for health effects**
- Numerous individual product standards have been written for PEX fitting designs
- Examples: ASTM F1807, ASTM F1960, ASTM F2080, ASTM F2159 and ASSE 1061

How PEX Tubing and Fittings Can Improve Health, Safety and Welfare



ASTM F1807 Crimp ring fitting
Available in brass or copper.



ASTM F1807 copper crimp ring
(not to scale!)



ASTM F2159 polymer crimp fitting
(black or white plastic)



Typical Crimp ring fitting assembly tool

ASTM F1807 Crimp Assembly



How PEX Tubing and Fittings Can Improve Health, Safety and Welfare

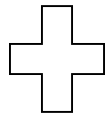

OR



ASTM F2098 stainless steel clamps are used with F1807 and F2159 crimp fittings as an alternative for the copper crimp ring.

ASTM F1807 brass fitting

ASTM F2159 polymer fitting



Special tools are used for these s/s clamps – each type of clamp specifies its own tool

How PEX Tubing and Fittings Can Improve Health, Safety and Welfare

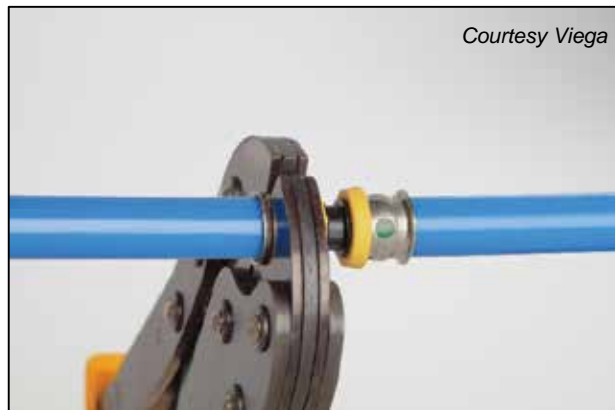

ASTM F3347/F3348 Press fittings using stainless steel sleeve.
Available in polymer and lead-free brass.



How PEX Tubing and Fittings Can Improve Health, Safety and Welfare



ASTM F1960 Cold-expansion fitting using a PEX ring.
Available in polymer and lead-free brass.



How PEX Tubing and Fittings Can Improve Health, Safety and Welfare



Cold-expansion fitting with PEX compression-sleeve.
Available in polymer and lead-free brass.



How PEX Tubing and Fittings Can Improve Health, Safety and Welfare

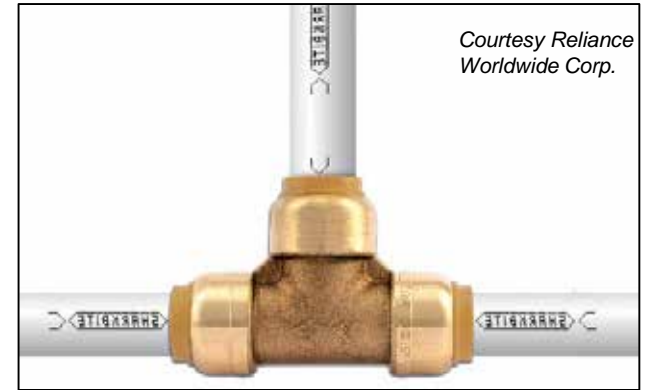

ASSE 1061 Push-fit fittings
Available in polymer and lead-free brass.



How PEX Tubing and Fittings Can Improve Health, Safety and Welfare



ASSE 1061 Push-fit fittings
Available in polymer and lead-free brass.



How PEX Tubing and Fittings Can Improve Health, Safety and Welfare



ASSE 1061 Push-fit non-removal fittings with internal stainless steel clamp.

Available in polymer.

Note: This style of ASSE 1061 fitting is for PEX and PE-RT tubing only, not for copper or CPVC.



How PEX Tubing and Fittings Can Improve Health, Safety and Welfare

Wide range of PEX fittings available

- Various adapters available: Copper sweat/street, MPT, FPT, etc.



How PEX Tubing and Fittings Can Improve Health, Safety and Welfare

Commercial Applications – Adapting to Other Piping Materials

- Various adapters available: Press fittings, Flanges, Grooved, MPT and FPT adapters

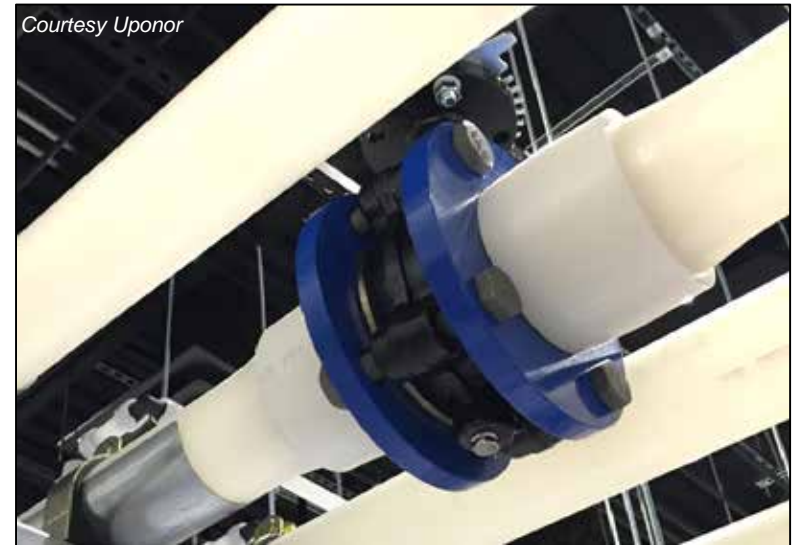

How PEX Tubing and Fittings Can Improve Health, Safety and Welfare

Commercial Applications – Adapting to Other Piping Materials



How PEX Tubing and Fittings Can Improve Health, Safety and Welfare

PEX Fittings Standards

- Keep in mind that **not all PEX fittings are approved for use with all PEX tubing**
 - **Some combinations are not approved!**
- Tubing manufacturers test and certify the specific fitting designs before they may recommend them for use with their tubing
- The standard designation(s) of the fitting system(s) for which the tubing is recommended by the tubing manufacturer and that is specifically qualified for use with PEX is marked on the tubing
- In other words, look for markings such as “F1807”, “F1960”, “F2080”, “F2159” or “ASSE 1061” on the tubing print line to show compatibility and approval

How PEX Tubing and Fittings Can Improve Health, Safety and Welfare

PEX Fittings Standards

- Look for markings such as “F1807”, “F1960”, “F2080”, “F2159” or “ASSE 1061” on the tubing print line to show compatibility and approval

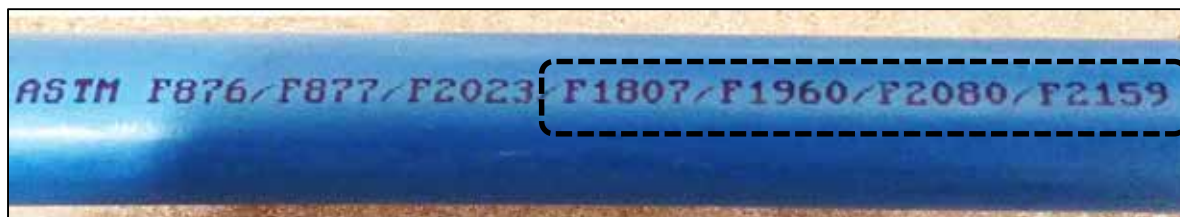
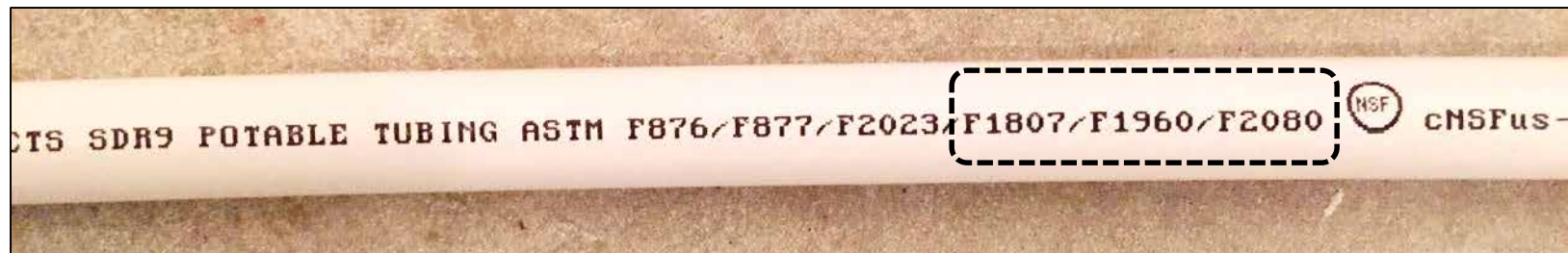

How PEX Tubing and Fittings Can Improve Health, Safety and Welfare

3. PEX Distribution Manifolds

- Several styles of manifolds are available in several materials
 - Copper, polymer*
 - Valved, valveless
- All manifolds must meet the same requirements as PEX fitting systems: **ASTM F877**

**Polysulfone (PLS) and polyphenylsulfone (PPSU) are thermoplastic polymers known for their toughness, stability at high temperatures, and chlorine resistance. These are the typical polymers used for fittings and manifolds as part of PEX systems.*

How PEX Tubing and Fittings Can Improve Health, Safety and Welfare

PEX Distribution Manifolds

- Several styles of manifolds are available in several materials
 - Copper, polymer
 - Valved, valveless
- More images in next Learning Objective



How PEX Tubing and Fittings Can Improve Health, Safety and Welfare

PEX Distribution Manifolds

- Several styles of manifolds are available in several materials
 - Copper, polymer
 - Valved, valveless
- More images in next LO



How PEX Tubing and Fittings Can Improve Health, Safety and Welfare

4. PEX Tubing Fasteners

- PEX tubing is extremely tough and durable and is compatible with several types of fasteners – usually plastic holders
- Manufacturers have preferred fasteners and some might have prohibited fasteners
- Contractors/installers have preferred fasteners for various construction types
- This topic will be addressed in greater detail in Learning Objective #4 “Installation”



Holders

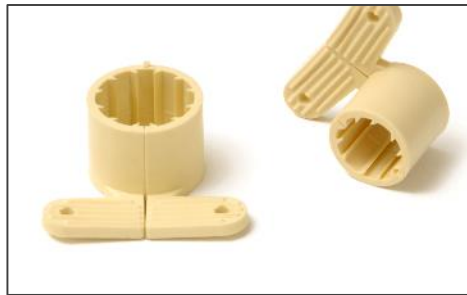

Isolators



PE Sleeving

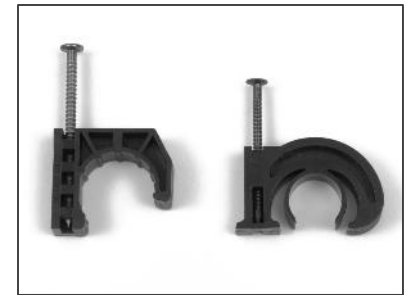

Talons

How PEX Tubing and Fittings Can Improve Health, Safety and Welfare

Summary: This Learning Objective explained the piping components

1. PEX Tubing: Crosslinked Polyethylene
2. PEX Fittings: Brass, copper and polymer materials, several designs
3. Plumbing Distribution Manifolds: Several designs and materials
4. Tubing Fasteners: Those intended for PEX plumbing systems



2. Plumbing Layouts Using PEX

This Learning Objective describes three layout options:

1. Trunk and Branch (a.k.a. traditional)
2. Parallel pipe systems (a.k.a. home run)
3. Zoned systems (a.k.a. remote manifolds)

By carefully choosing the right system for the application, the plumbing designer can produce a home that balances longevity, comfort, cost, installation time, environmental soundness and performance

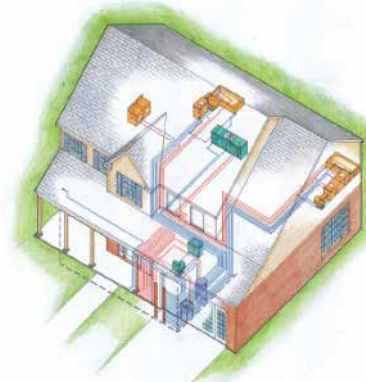

Plumbing Layouts Using PEX

Trunk and Branch (a.k.a. traditional)

- **Trunk and Branch** is a familiar installation technique
- Employs normal use of reducing tees and elbows
 - Most elbows are eliminated with bends
- Traditional installation technique is faster due to tubing flexibility and faster joint assembly
- PEX tubing sizes up to 3" are available, drops are typically 3/4", 1/2" or 3/8"
- T&B layouts are most appropriate when using larger diameter PEX (over 3/4") where flexibility is not so relevant
- T&B is commonly used in commercial plumbing design

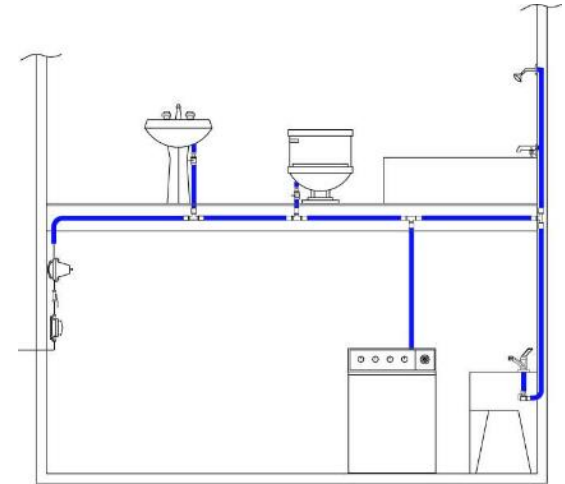

Plumbing Layouts Using PEX

Parallel pipe systems (a.k.a. home run)

- **Parallel** technique employs 3/8" or 1/2" pipes which are "home-run" to each fixture
 - Small tubing of one size is easy to install
- Tubing is connected to central manifolds (hot and cold)
 - Manifolds (often valved) are located near the source
- Sizing is simplified, systems are pressure-balanced
- Fewer fittings are required (none within walls) and tees are practically eliminated (still used for dishwasher)
- Similar in concept to household wiring from a breaker panel

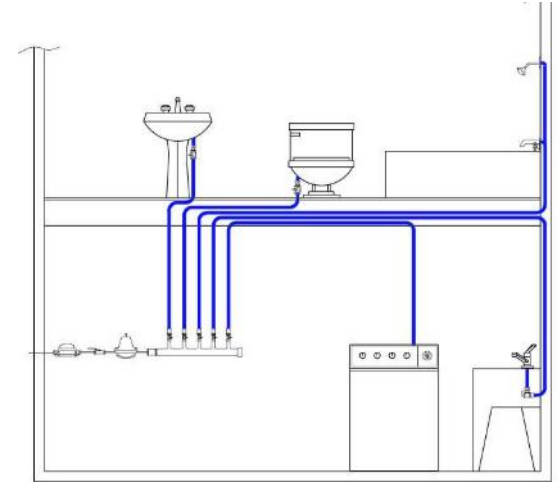

Plumbing Layouts Using PEX

Zoned systems (a.k.a. remote manifolds)

- **Zoned** technique uses trunk lines to supply remote manifolds at fixture group “zones”
 - Small manifolds replace many tees and joints
 - 3/8” or 1/2” pipes run to each fixture
- Manifolds are copper or polymer, usually not valved
 - Often embedded within walls
- Sizing is simplified, systems are pressure-balanced
- Fewer fittings are required and tees are practically eliminated (still used at dishwasher)

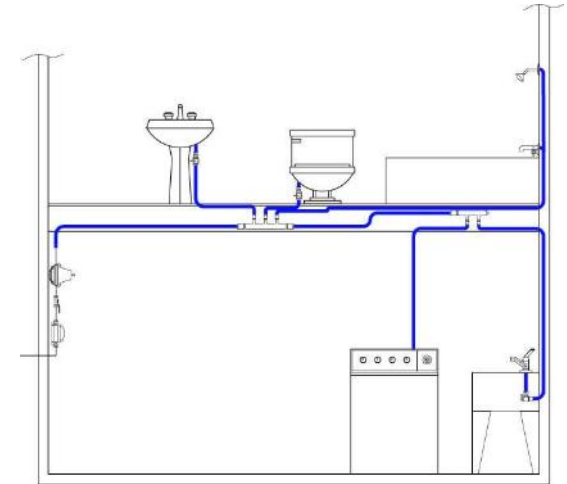

Plumbing Layouts Using PEX

Comments on Trunk and Branch

- Although PEX tubing works well in a traditional T&B layout and is very appropriate for commercial installations, it might be the slowest installation technique
- Experienced plumbers may reduce installation time and/or materials in one of the other techniques
- **T&B systems** may be ideal for certain designs, especially large-diameter commercial plumbing

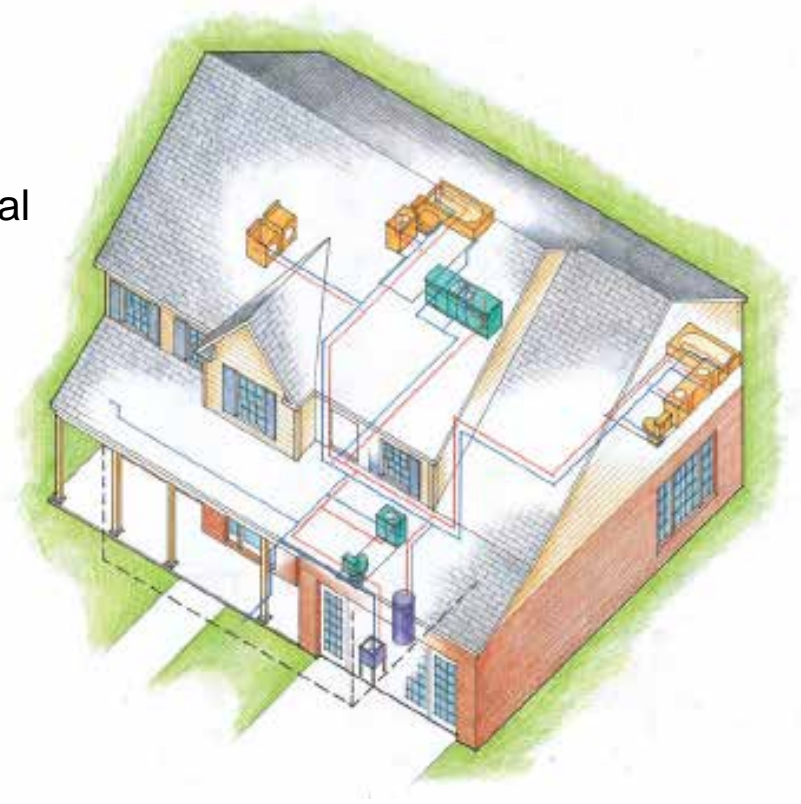

Plumbing Layouts Using PEX

Comments on Parallel systems

- Although PEX tubing works well in a parallel home-run layout, this technique requires a lot of tubing, many holes in studs and plates, greater need for fasteners, and potentially longer installation time
- Delivery time for sequential hot-water has no advantage over T&B
- **Parallel systems** may be ideal for certain designs, especially small residential systems, shorter lengths

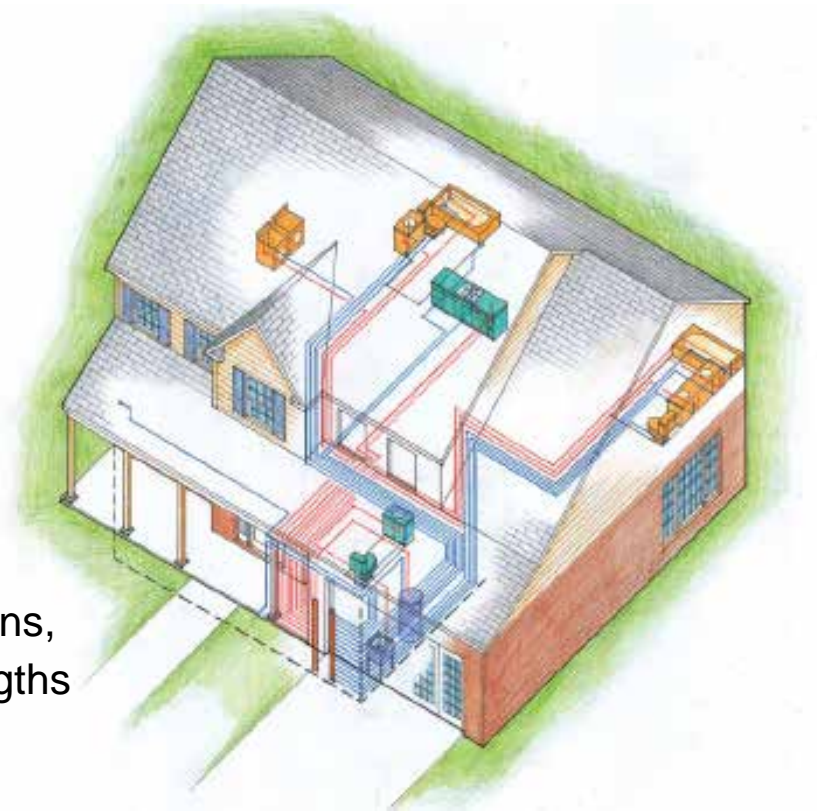

Plumbing Layouts Using PEX

Comments on Parallel systems

- Although PEX tubing works well in a parallel home-run layout, this technique requires a lot of tubing, many holes in studs and plates, greater need for fasteners, and potentially longer installation time
- Delivery time for sequential hot-water has no advantage over T&B
- **Parallel systems** may be ideal for certain designs, especially small residential systems, shorter lengths



Plumbing Layouts Using PEX

Comments on Parallel systems

- Although PEX tubing works well in a parallel home-run layout, this technique requires a lot of tubing, many holes in studs and plates, greater need for fasteners, and potentially longer installation time
- Delivery time for sequential hot-water has no advantage over T&B
- **Parallel systems** may be ideal for certain designs, especially small residential systems, shorter lengths



Plumbing Layouts Using PEX

Comments on Zoned systems

- The Zoned technique reduces the total amount of tubing, reduces number of fittings and can reduce overall installation time
- Delivery time for sequential hot-water is reduced over T&B and Parallel

- **Zoned systems** may be ideal for certain designs, especially when recirculation is employed

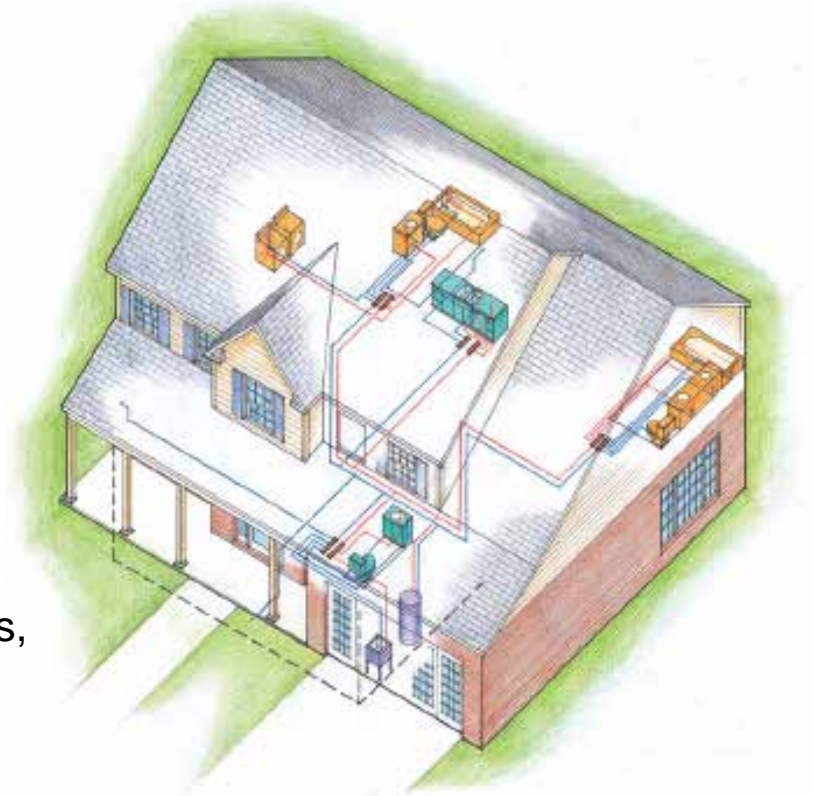

Plumbing Layouts Using PEX

Quick Comparison from PEX Plumbing Design Guide

- The designer assigns priorities, and can select the optimal layout using **Table 7.1**

Table 7.1 – General Rankings of the System Characteristics			
Factor	***	**	*
Minimize Pipe Used	Trunk and Branch	Zone	Parallel
Minimize Fittings and Joints	Parallel	Zone	Trunk and Branch
Sequential Flow Hot Water Delivery Time	Trunk and Branch Zone		Parallel
Minimize Hot Water Wait Time	Parallel	Zone	Trunk and Branch
Single Fixture Pressure	Trunk and Branch	Parallel Zone	
Pressure Stability with Use of Multiple Fixtures	Parallel	Zone	Trunk and Branch
Centralize Shut-off Valving	Parallel	Zone	Trunk and Branch
Joint Accessibility During Installation	Parallel	Zone	Trunk and Branch
*** Indicates the highest level of performance for that factor * Indicates typical performance			

Plumbing Layouts Using PEX

Volume and Weights of PEX Tubing Sizes

- The volume* of PEX tubing sizes should also be considered when designing layout of plumbing systems to minimize water waste/volume between fixtures and source

Tube Size (nominal)	Tube OD (average) in. *	Wall thickness (average) in. *	Tube ID (average) in. *	Weight of tube only, pounds per foot	Weight of tube & water, pounds per foot	Volume per ft. (gallon)	Volume per 100 ft. (gallon)
3/8	0.500	0.075	0.350	0.04	0.08	0.005	0.5
1/2	0.625	0.075	0.475	0.05	0.13	0.090	0.9
3/4	0.875	0.102	0.671	0.10	0.25	0.018	1.8
1	1.125	0.132	0.862	0.17	0.42	0.030	3.0
1 1/4	1.375	0.161	1.054	0.25	0.63	0.045	4.5
1 1/2	1.625	0.191	1.244	0.35	0.88	0.063	6.3
2	2.125	0.248	1.629	0.60	1.50	0.108	10.8
2 1/2	2.625	0.307	2.011	0.92	2.29	0.165	16.5
3	3.125	0.364	2.397	1.29	3.24	0.235	23.5

*Based on average OD and wall thickness dimensions as per ASTM F876/CSA B137.5

Plumbing Layouts Using PEX

Volume and Weights of PEX Tubing Sizes

- BCD Calculator also does Volume* of PEX tubing sizes. Example: ¾ nominal PEX



Plastic Pressure Pipe Design Calculator

PIPE WEIGHT / VOLUME

Input

Pipe Selection: PEX (ASTM F876/CSA B137.5) ▼

SDR 9 ▼ 3/4" ▼

Length Of Pipe: 60 ft

Fluid Type (Water or % Glycol): 100% Water ▼

Results

Dry Weight:	6.1 lb	2.8 kg
Filled Weight:	15.3 lb	6.9 kg
Volume Of Fluid In Pipe:	1.1 US Gallons	4.2 L
Volume Of Glycol:	0.0 US Gallons	0.0 L

Calculation Details

 Print
 Email

Images from www.plasticpipecalculator.com

*Based on average OD and wall thickness dimensions as per ASTM F876/CSA B137.5

Plumbing Layouts Using PEX

Volume and Weights of PEX Tubing Sizes

- BCD Calculator also does Volume* of PEX tubing sizes. Example: 1 ½ nominal PEX



Plastic Pressure Pipe Design Calculator

PIPE WEIGHT / VOLUME

Input

Pipe Selection: PEX (ASTM F876/CSA B137.5) ▼

SDR 9 ▼ 1 1/2" ▼

Length Of Pipe: 60 ft

Fluid Type (Water or % Glycol): 100% Water ▼

Results

Dry Weight:	21.1 lb	9.6 kg
Filled Weight:	52.6 lb	23.9 kg
Volume Of Fluid In Pipe:	3.8 US Gallons	14.3 L
Volume Of Glycol:	0.0 US Gallons	0.0 L

Calculation Details
 Print
 Email

Images from www.plasticpipecalculator.com

*Based on average OD and wall thickness dimensions as per ASTM F876/CSA B137.5

Plumbing Layouts Using PEX

Summary: This Learning Objective described 3 layout options

1. Trunk and Branch (a.k.a. traditional)
2. Parallel pipe systems (a.k.a. home run)
3. Zoned systems (a.k.a. remote manifolds)

In Learning Objective #3 we'll see how to optimize designs

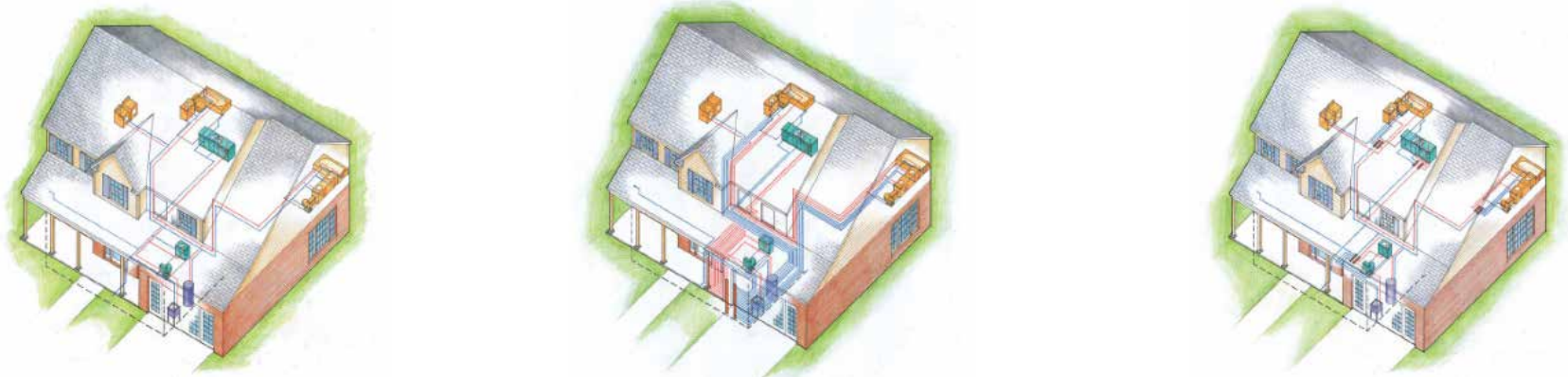

3. Optimizing Design

This Learning Objective discusses performance of the three layout options (Learning Objective #2) for four types of residences:

- 1. Colonial:** 2,000 square feet, basement, two levels, 4 BR, 2 full baths
- 2. Ranch:** 1,300 square feet, one story, 2 full baths
- 3. Townhouse:** 1,000 square, three levels, 1 full bath, 1 half bath
- 4. Condo:** 1,200 square feet, one level, 2 full baths

- The opportunity for the plumbing designer is to select the system that balances the needs of the installer, the builder and the owner/occupant for an **optimized system**

Optimizing Design

The primary goal of hot-water plumbing is to deliver hot water as soon as possible with minimal waste

- Good plumbing design can help to achieve this goal
- Also important is the architecture/design of the house as related to plumbing

For example:

1. Group fixtures together in a common location, stacking bathrooms
2. Centrally locate the distribution points for hot and cold water
3. Create spaces for bundled pipe runs
 - For Parallel piping, group pipes together (hot-with-hot, cold-with-cold)
4. Insulate pipes where necessary
 - Although PEX tubing is an insulator as compared with copper, code requirements and common sense still apply
 - *See PPI TR-48 R-Value and Thermal Conductivity of PEX and PE-RT*

Optimizing Design

ASPE Time-to-Tap Performance Criteria

Volume in the Pipe (ounces)	Minimum Time-to-Tap (seconds) at Selected Flow Rates					
	0.25 gpm	0.5 gpm	1 gpm	1.5 gpm	2 gpm	2.5 gpm
2	4	1.9	0.9	0.6	0.5	0.4
4	8	4	1.9	1.3	0.9	0.8
8	15	8	4	2.5	1.9	1.5
16	30	15	8	5	4	3
24	45	23	11	8	6	5
32	60	30	15	10	8	6
64	120	60	30	20	15	12
128	240	120	60	40	30	24

With proper design, PEX plumbing systems can help to reduce wait time for hot water

	Acceptable Performance	≤ 10 seconds
	Marginal Performance	> 10 ≤ 30 seconds
	Unacceptable Performance	> 30 seconds

Source: Domestic Water Heating Design Manual – 2nd Edition, ASPE, 2003, page 234

Optimizing Design

The next slides show how the **DESIGN GUIDE** compares three layout options for four types of residences, both graphically and quantitatively:

1. **Colonial:** 2,000 square feet, basement, two levels, 4 BR, 2 full baths
2. **Ranch:** 1,300 square feet, one story, 2 full baths
3. **Townhouse:** 1,000 square, three levels, 1 full bath, 1 half bath
4. **Condo:** 1,200 square feet, one level, 2 full baths



Optimizing Design

Colonial: 2,000 square feet, basement, two levels, 4 BR, 2 full baths

- Trunk and Branch Design

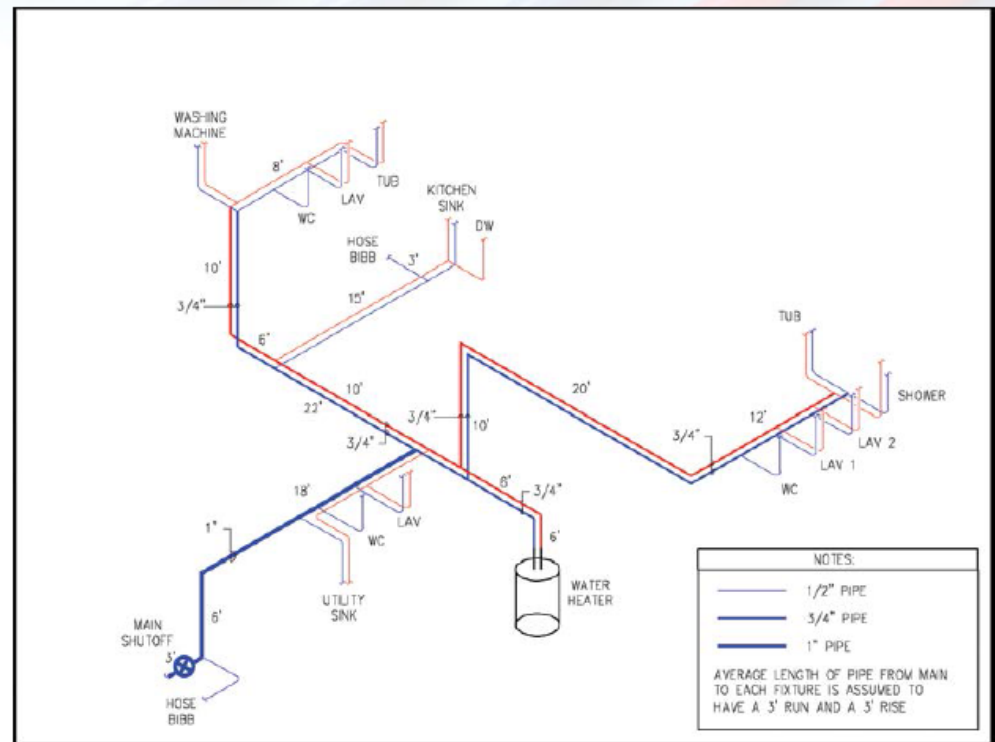

Optimizing Design

Colonial: 2,000 square feet, basement, two levels, 4 BR, 2 full baths

- Parallel Design (home run)

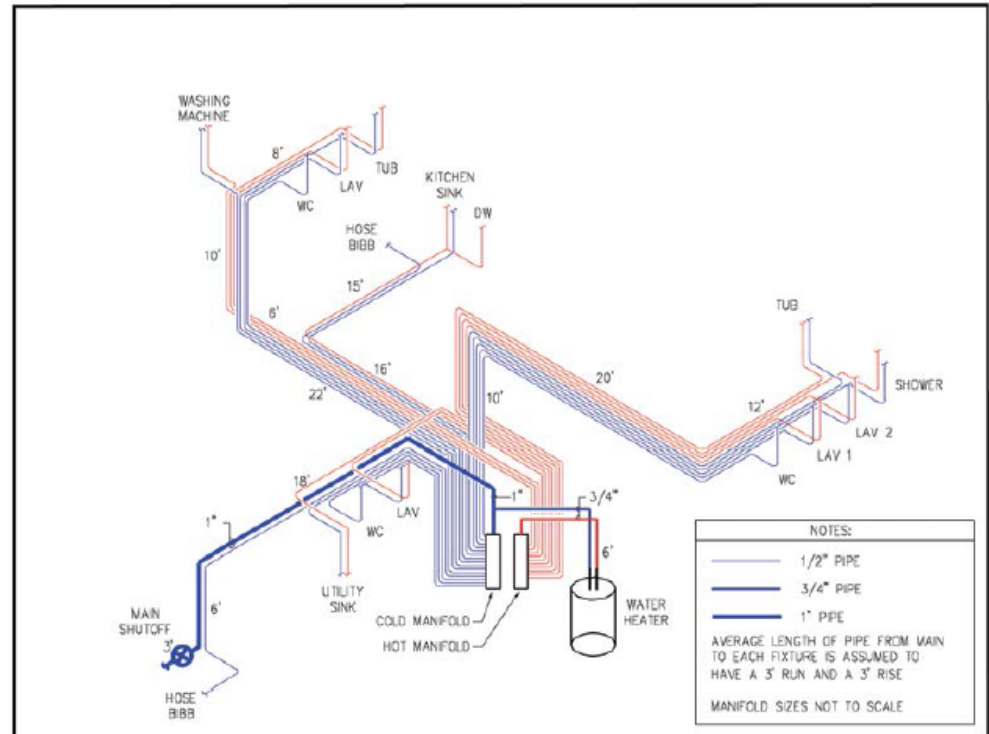

Optimizing Design

Colonial: 2,000 square feet, basement, two levels, 4 BR, 2 full baths

- Material Summary in **Table 7.4**

Table 7.4 – Material Summary for the Colonial House												
System	Length of Cold Pipe			Length of Hot Pipe			Fittings		Manifolds/ Multi-port Tees		Joints	
	1"	3/4"	1/2"	1"	3/4"	1/2"	Tees	Elbows	Main	Remote	Fixtures	Piping
Trunk and Branch	27'	80'	110'	0'	80'	98'	25	10	0	0	26	97
Parallel	33'	12'	602'	0'	12'	428'	2	7	2	0	26	49
Zone	27'	93'	152'	0'	93'	107'	8	13	0	7	26	83

Optimizing Design

Ranch: 1,300 square feet, one story, 2 full baths

- Three designs were compared

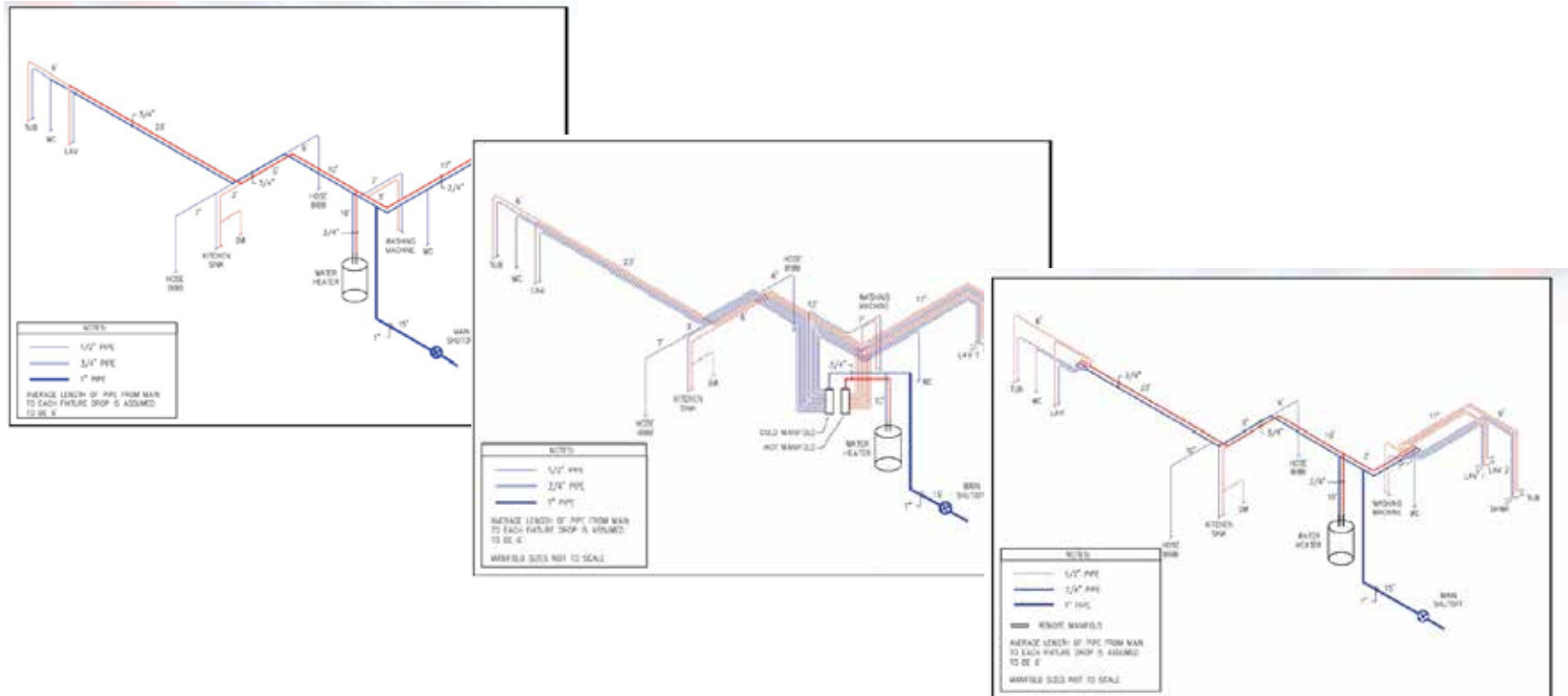

Optimizing Design

Ranch: 1,300 square feet, one story, 2 full baths

- Material Summary in **Table 7.6**

Table 7.6 – Material Summary for the Ranch House												
System	Length of Cold Pipe			Length of Hot Pipe			Fittings		Manifolds/ Multi-port Tees		Joints	
	1"	3/4"	1/2"	1"	3/4"	1/2"	Tees	Elbows	Main	Remote	Fixtures	Piping
Trunk and Branch	25'	75'	112'	0'	72'	81'	20	5	0	0	21	71
Parallel	25'	10'	413'	0'	10'	294'	2	5	2	0	21	39
Zone	25'	59'	196'	0'	59'	159'	8	4	0	4	21	53

Optimizing Design

Townhouse: 1,000 square, three levels, 1 full bath, 1 half bath

- Material Summary in **Table 7.8**

Table 7.8 – Material Summary for the Townhouse												
System	Length of Cold Pipe			Length of Hot Pipe			Fittings		Manifolds/ Multi-port Tees		Joints	
	1"	3/4"	1/2"	1"	3/4"	1/2"	Tees	Elbows	Main	Remote	Fixtures	Piping
Trunk and Branch	0'	66'	86'	0'	30'	44'	14	8	0	0	15	59
Parallel	0'	42'	247'	0'	11'	138'	2	8	2	0	15	39
Zone	0'	67'	100'	0'	30'	44'	5	7	0	2	15	42

Optimizing Design

Condo: 1,200 square feet, one level, 2 full baths

- Material Summary in **Table 7.10**

Table 7.10 – Material Summary for the Condominium												
System	Length of Cold Pipe			Length of Hot Pipe			Fittings		Manifolds/ Multi-port Tees		Joints	
	1"	3/4"	1/2"	1"	3/4"	1/2"	Tees	Elbows	Main	Remote	Fixtures	Piping
Trunk and Branch	0'	45'	120'	0'	45'	104'	17	0	0	0	19	53
Parallel	0'	10'	295'	0'	10'	242'	1	2	2	0	19	29
Zone	0'	35'	132'	0'	35'	115'	5	0	0	4	19	37

PEX Plumbing System Performance

Measuring Performance

- *Home Innovations* built a simulated house in their plumbing lab and measured results
- Same simulated house, plumbed three ways:
 - Trunk & Branch
 - Parallel
 - Zoned

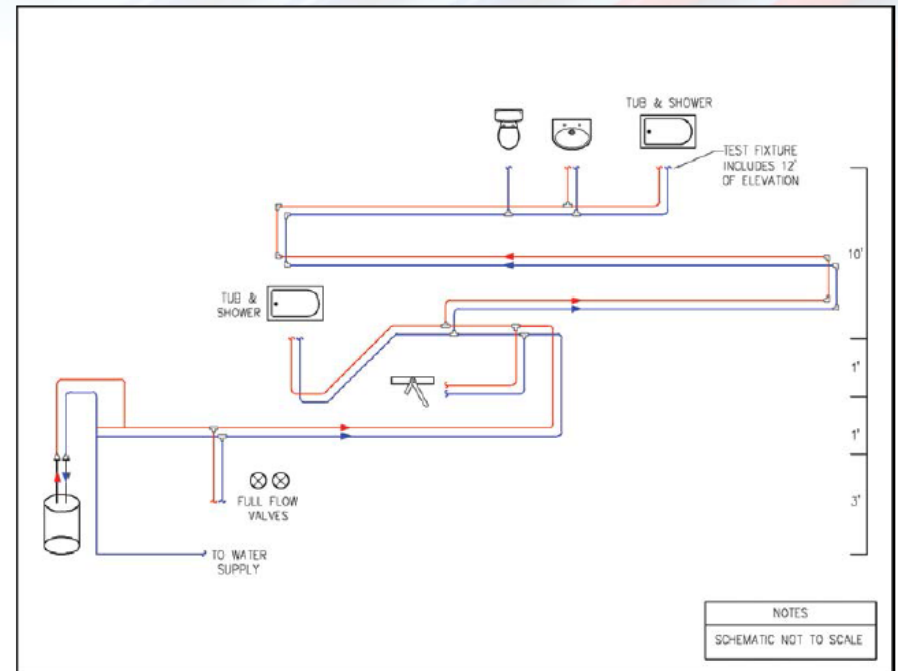

Figure 8.1 – Fixture Layout for Laboratory Testing

PEX Plumbing System Performance

Measuring Performance

- *Home Innovations* built a simulated house in their plumbing lab and measured results
- Same simulated house, plumbed three ways:

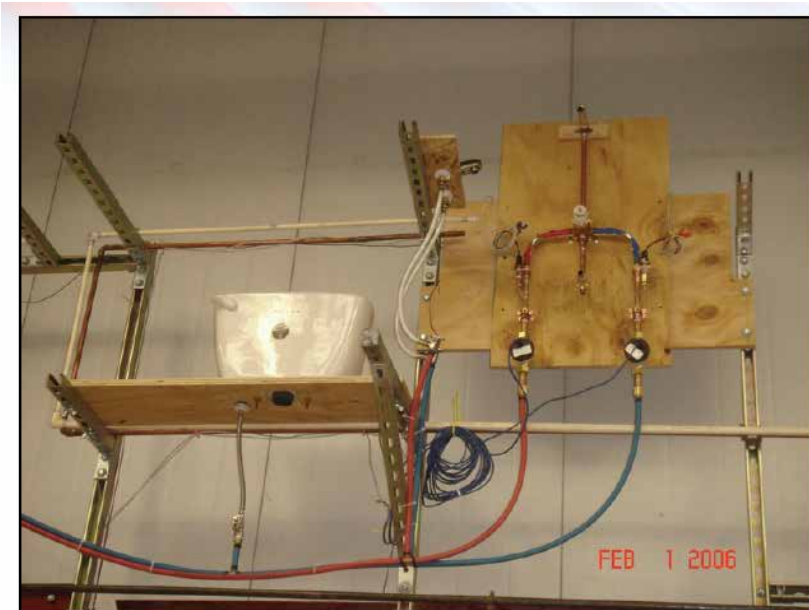

Figure 8.3 – The Test Fixture (Shower) with Flow and Pressure Sensors Installed



Figure 8.2 – Laboratory Test Set-up with Five Outlets, Hot Water Tank, and T&B System

PEX Plumbing System Performance

A. Pressure Drop

- See Chapter 7 “Design” (page 56)

Performance Verification Laboratory Testing

A set of laboratory tests using typical plumbing fixtures and plumbing pipe sizes, runs and fittings was performed to demonstrate the flow characteristics of the three different PEX systems. Results of this testing indicate that all three systems will supply adequate pressure and water delivery to a remote shower fixture located 100 feet from the base riser with an elevation head of 15 feet. Base source pressures of 40, 60, and 80 psi were used in each of the different system designs. Multiple tests were performed to add simultaneous flows from other fixtures including a shower, lavatory, kitchen and water closet. Test results are shown in Chapter 8.

PEX Plumbing System Performance

A. Pressure Drop

- See Chapter 8 “Performance Data” (page 71)

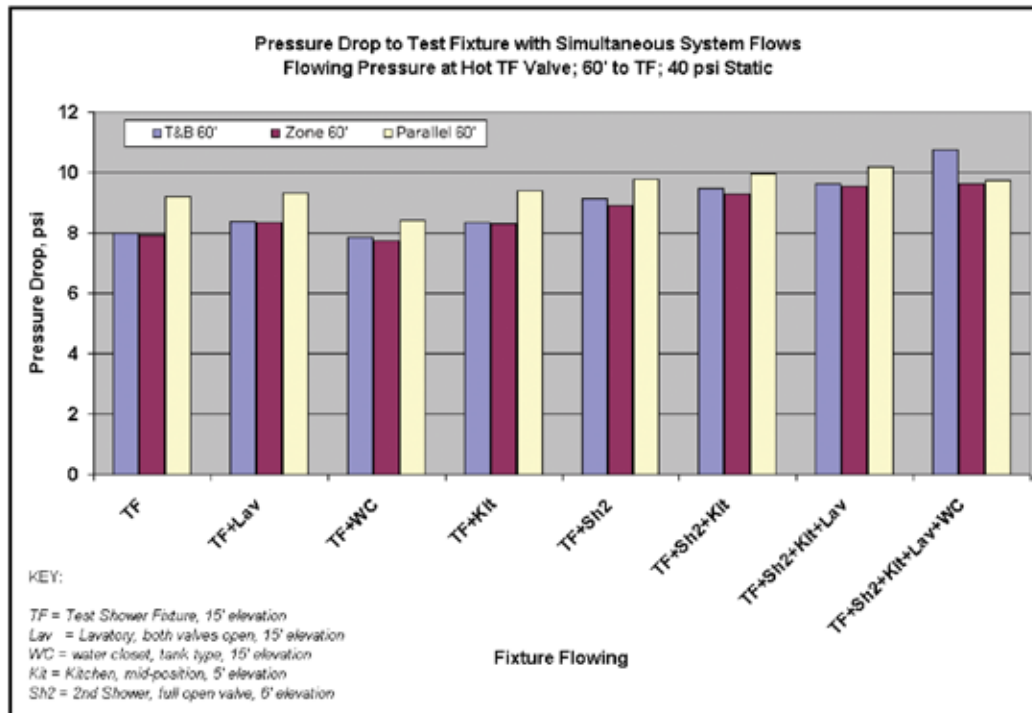

Figure 8.5 – Pressure Drop Comparison, 60' Distance to TF

PEX Plumbing System Performance

B. Flow Rate

- See Chapter 8 “Performance Data” (page 75)

PEX and Copper Pipe Flow Rates

Laboratory testing was performed on identical configurations of PEX and copper trunk and branch (T&B) plumbing systems serving standard residential plumbing fixtures supplied at source pressures of 40, 60, and 80 psi, with lengths of 60 and 100-feet of pipe to the furthest fixture. The measured flow rate at each plumbing fixture was virtually identical for both piping systems, except for minor differences in the water closet fill rate.

Even though PEX tubing has a slightly smaller inside diameter than copper tubing of the same nominal dimension, both tubing systems satisfied the farthest fixture demand, even with multiple fixtures flowing. The following Table compares the two piping systems with a minimum source pressure of 40 psi, the most demanding scenario in the test. Results of tests using higher pressures were consistent.

Results of this testing demonstrate that in a typical single-family residential plumbing system, both PEX and copper piping systems will deliver sufficient volumetric flow rates and pressures to the plumbing fixtures when using the same nominal size tubing.

PEX Plumbing System Performance

B. Flow Rate

- See also NAHB report “Fixture Flow Rate Comparison: PEX and Copper Tubing” PEX tubing can typically be installed in place of copper pipes on a **size-for-size** basis
 - Fixtures actually control the flow!
 - Many pipe designs are oversizing pipes today
- The ID of PEX tubing is slightly less than copper
- Ex: 0.480” vs. 0.500” for ½ in. nominal – **96%**
- Thanks to its smooth wall and elimination of most elbows, codes allow for size-for-size replacement for PEX

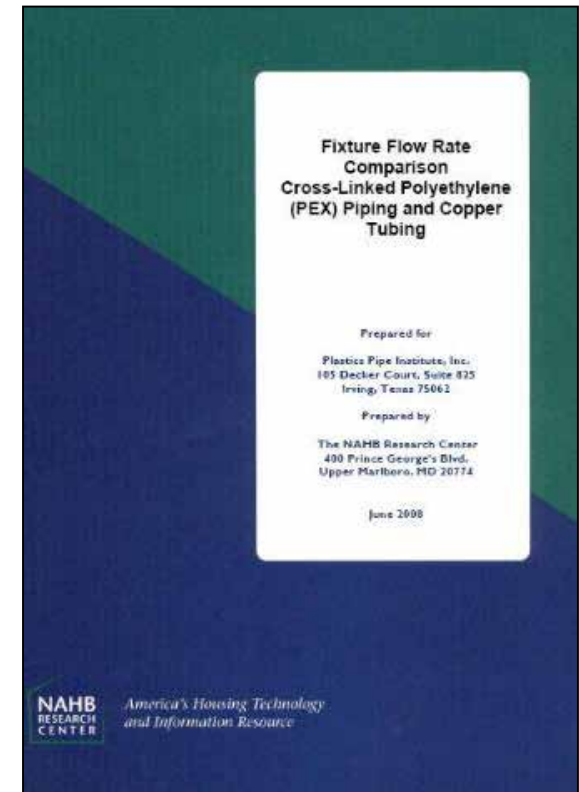

PEX Plumbing System Performance

C. Surge Pressure/Water hammer

- See Chapter 8 “Performance Data” (page 74)

PEX Pipe Response to Surge Pressure (Water Hammer)

A benefit of flexible piping systems is the ability to mitigate or absorb pressure surges in plumbing systems, such as what can occur when flowing water is stopped by a fast-acting valve. To quantify this benefit, a test apparatus was constructed and operated such that pressurized flowing water in a 20-foot straight length of pipe was abruptly interrupted by a fast-acting solenoid valve. Several rigid and flexible, metal and plastic, nominal one-half inch diameter pipe materials were subjected to a test regime that included flow rates as high as 6 gallons per minute, using cold and hot water supplies.

For example, test results using nominal half-inch pipes with “cold” water at a typical flow rate of 2.5 GPM showed that peak pressures were reduced by up to 37% for PEX pipes as compared with copper pipes. Test results using nominal half-inch pipes with “hot” water at a typical flow rate of 2.5 GPM showed that peak pressures were reduced by up to 33% for PEX pipes as compared with copper pipes. Results are shown in Tables 8.7 and 8.8. At higher flow rates, the percentage of the surge pressure reduction increases.

PEX Plumbing System Performance

C. Surge Pressure/Water hammer

- See also NAHB report “Surge Pressure in Plumbing Pipe Materials”

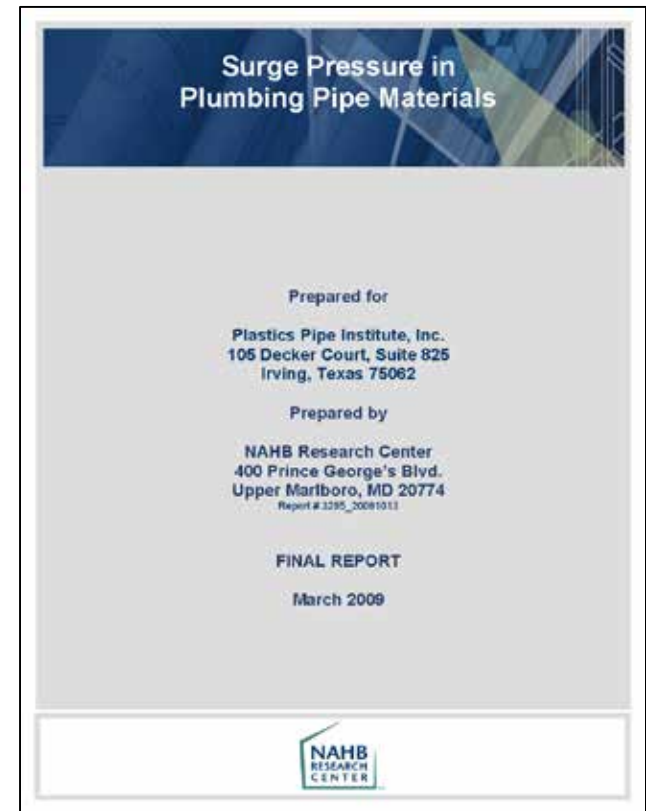
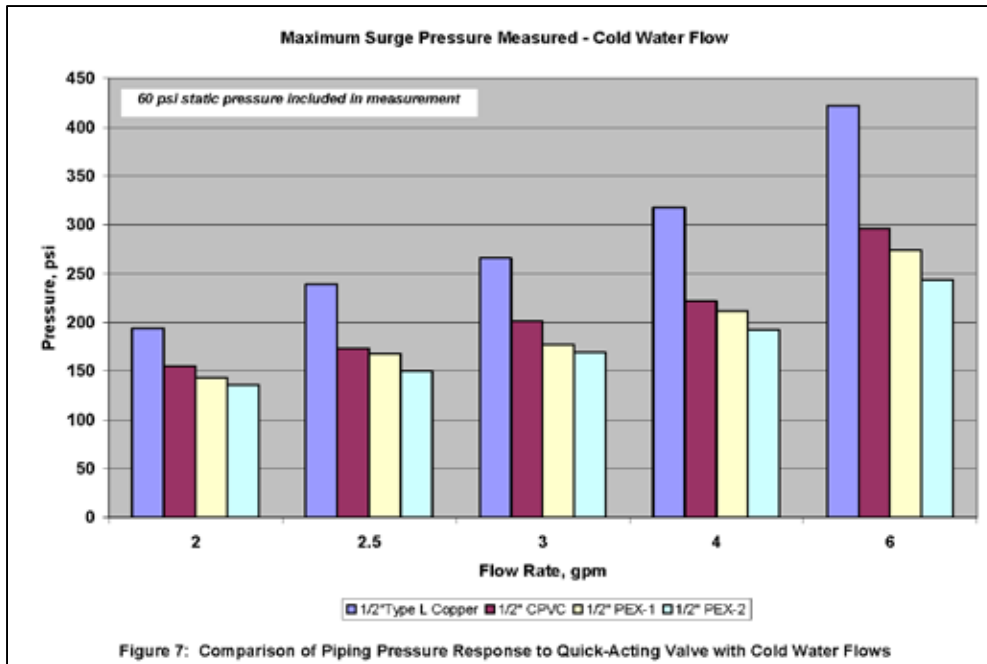

PEX Plumbing System Performance

C. Surge Pressure/Water hammer

- See also NAHB report “Surge Pressure in Plumbing Pipe Materials”

**Table 3: Peak Pressure Comparison – 2.5 GPM Cold Water Flow, 54°F Water
(See Figure 4b)**

	Pipe Peak 1 (psig)	% Difference
½" Type L Copper	239	0
½" CPVC	173	28
½" PEX-1	168	30
½" PEX-2	150	37

**Table 4: Peak Pressure Comparison – 2.5 GPM Hot Water Flow, 130°F Water
(see Figure 5b)**

	Pipe Peak 1 (psig)	% Difference
½" Type L Copper	181	0
½" CPVC	149	18
½" PEX-1	113	38
½" PEX-2	109	40

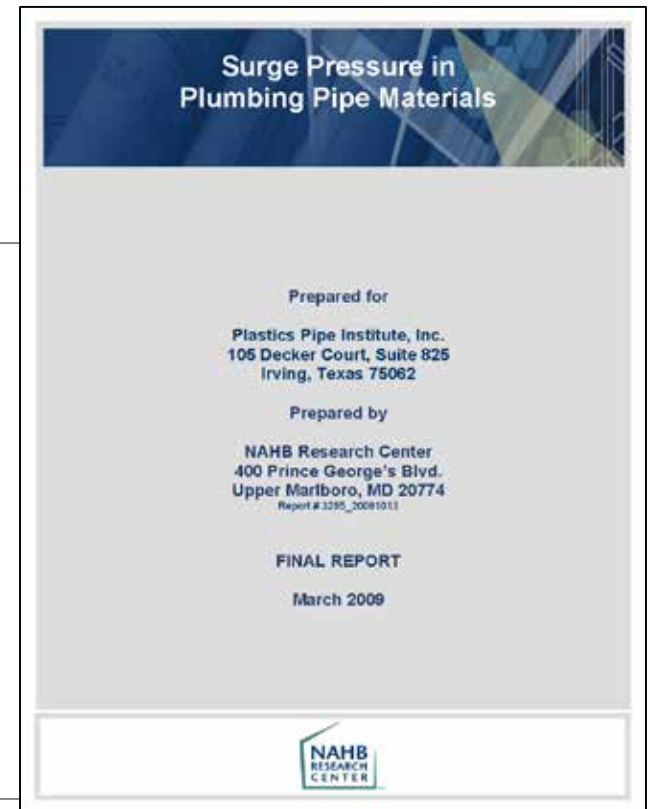

Optimizing Design

Measuring Performance

- *Home Innovations* built a simulated house in their plumbing lab and measured results
- Same simulated house, plumbed three ways:
 - Trunk & Branch
 - Parallel
 - Zoned

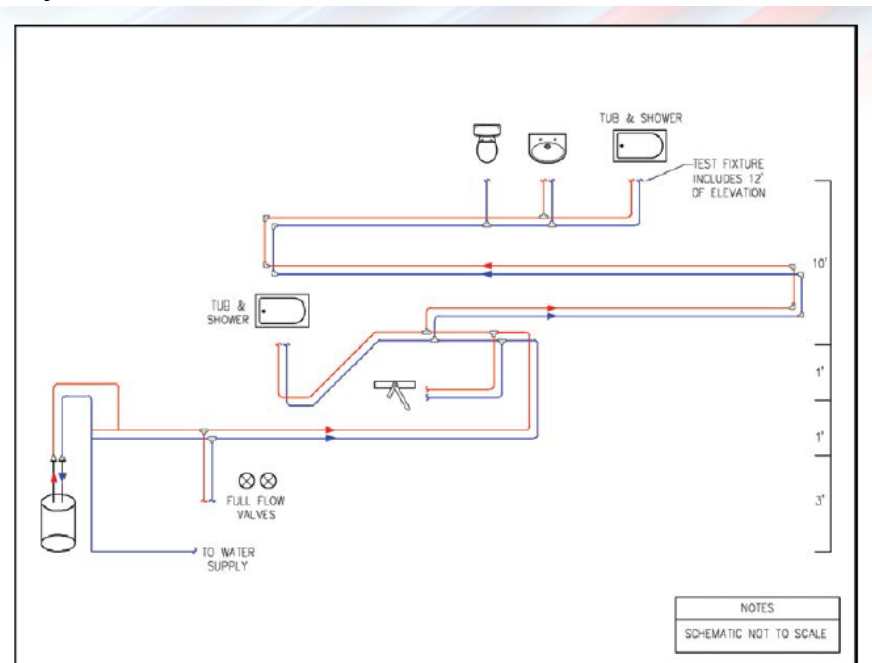
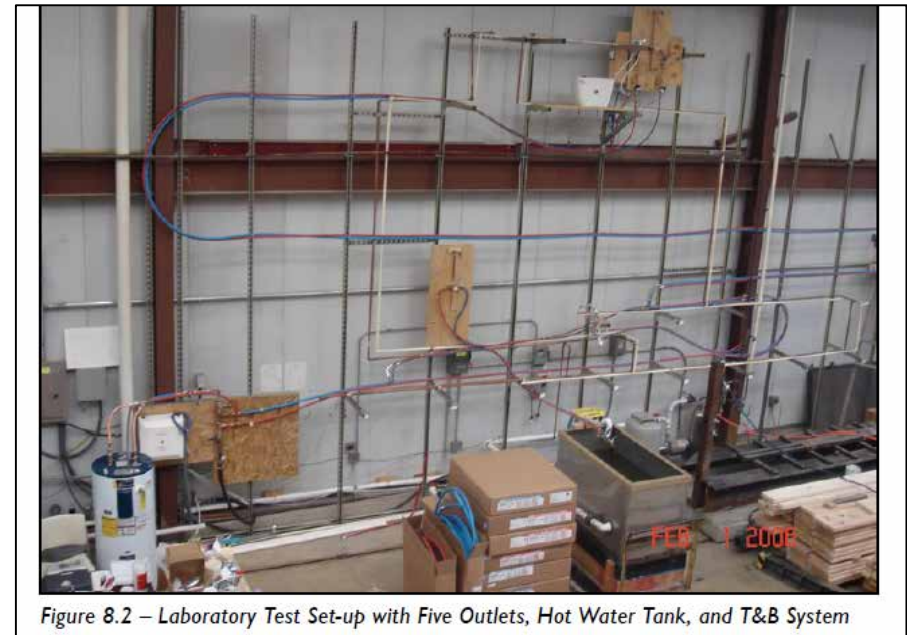
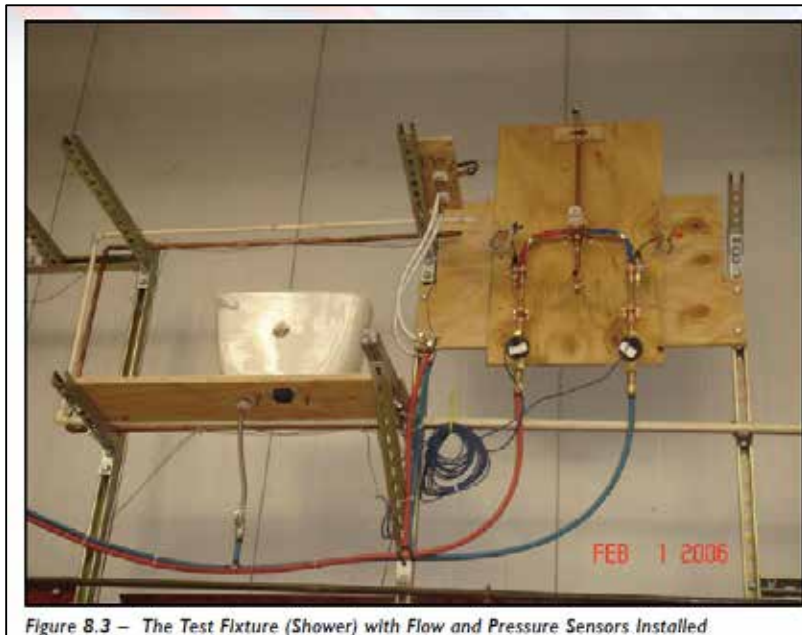

Figure 8.1 – Fixture Layout for Laboratory Testing

Optimizing Design

Measuring Performance

- *Home Innovations* built a simulated house in their plumbing lab and measured results
- Same simulated house (Colonial), plumbed three ways:



Optimizing Design

Measuring Performance: Wait Time for Hot Water, from **53°F** to **110°F**:

- **Distance of 60 ft.**
 - T&B: 53 sec
 - Parallel: 37 sec
 - Zoned: 53 sec
- Parallel is faster by **30%**

- **Distance of 100 ft.**
 - T&B: 92 sec
 - Parallel: 56 sec
 - Zoned: 89 sec
- Parallel is faster by **38%**

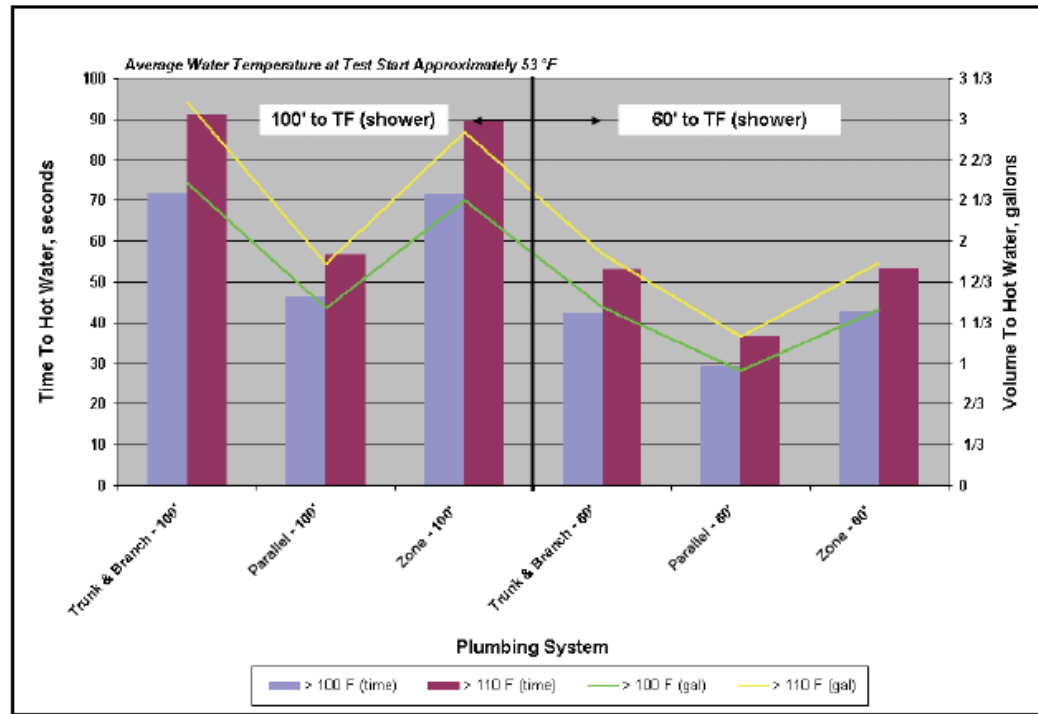

Figure 8.6 – Comparison of Hot Water Delivery Time

Optimizing Design

Measuring Performance: Test Summary

- **T&B** will supply one fixture at a higher pressure, but **Parallel** will supply a more stable pressure to each fixture when operating simultaneous fixtures
- **Parallel** delivers hot water faster, especially when starting from cold
- **T&B** and **Zoned** systems deliver hot water faster during sequential flows
- **All three designs delivered sufficient flow and pressure** even with base pressure of just 40 psi, and a length to farthest outlet of 100 ft.
- **DESIGN GUIDE** includes measured data about pressures

Optimizing Design

Notes on Tube Sizing

- According to NAHB report “Fixture Flow Rate Comparison: PEX and Copper Tubing” PEX tubing can typically be installed in place of copper pipes on a **size-for-size** basis
 - Fixtures actually control the flow!
 - Many pipe designs are oversizing pipes today
- Although the ID of PEX tubing is slightly less than copper (e.g. 0.485” vs. 0.500” for ½ in. nominal), thanks to smooth wall and elimination of most elbows, codes allow for size-for-size replacement
- Details in [DESIGN GUIDE](#)

Exception: Alternate system designs may actually reduce pipe diameter requirements

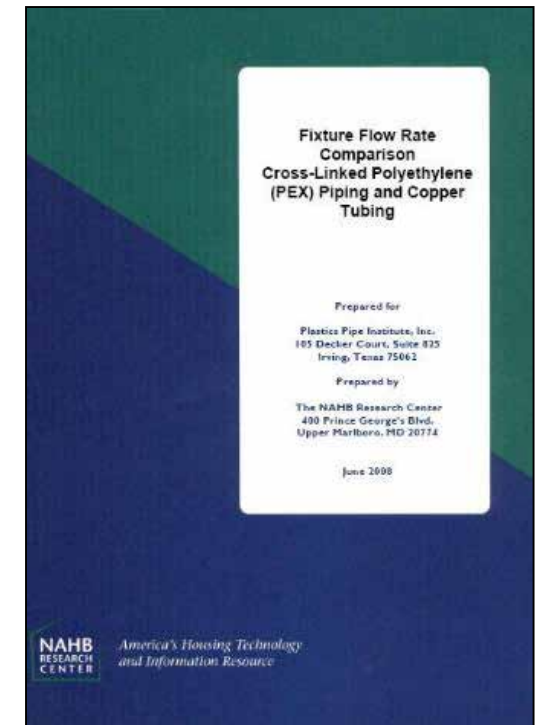

Optimizing Design

Summary: This Learning Objective discussed performance of the three layout options for four types of residences

1. Colonial: 2,000 square feet, basement, two levels, 4 BR, 2 full baths
2. Ranch: 1,300 square feet, one story, 2 full baths
3. Townhouse: 1,000 square, three levels, 1 full bath, 1 half bath
4. Condo: 1,200 square feet, one level, 2 full baths

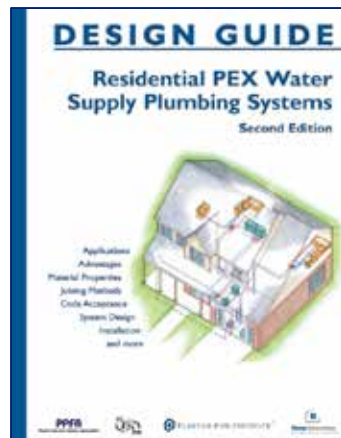

Access the data as demonstrated in the **DESIGN GUIDE** to compare design options for any type of building

4. Installation Techniques

This Learning Objective discusses correct installation techniques for PEX plumbing systems

1. Bending and flexibility
2. Fasteners
3. Protection
4. Installation under slabs
5. Linear expansion and contraction
6. Pressure testing



Installation Techniques

Bending and Flexibility

- Minimum bending radius is **6 to 8 times** the Outside Diameter of the tube
- Consult with tubing manufacturer for the exact minimum bend radius

For example:

Tube Size (nominal) in.	Tube OD (actual) in.	6X Minimum Bend Radius in.	8X Minimum Bend Radius in.
3/8	0.500	3.0	4.0
1/2	0.625	3.8	5.0
3/4	0.875	5.3	7.0
1	1.125	6.8	9.0
1 1/4	1.375	8.3	11.0
1 1/2	1.625	9.8	13.0
2	2.125	12.8	17.0



Installation Techniques

Bending and Flexibility

- Minimum bending radius is **6 to 8 times** the Outside Diameter of the tube
- Consult with tubing manufacturer for the exact minimum bend radius

For example:

Tube Size (nominal) in.	Tube OD (actual) in.	6X Minimum Bend Radius in.	8X Minimum Bend Radius in.
3/8	0.500	3.0	4.0
1/2	0.625	3.8	5.0
3/4	0.875	5.3	7.0
1	1.125	6.8	9.0
1 1/4	1.375	8.3	11.0
1 1/2	1.625	9.8	13.0
2	2.125	12.8	17.0

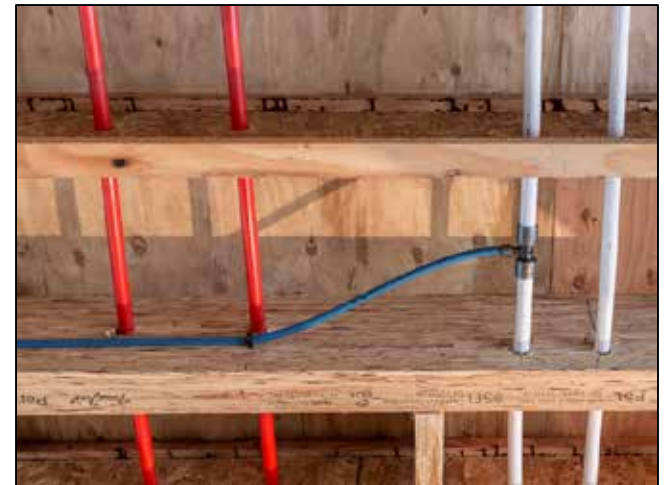

Installation Techniques

Bending and Flexibility

- Bend supports/support bends/sweeps may be used to replace most elbows
- These accessories can save the time and cost of installing elbows

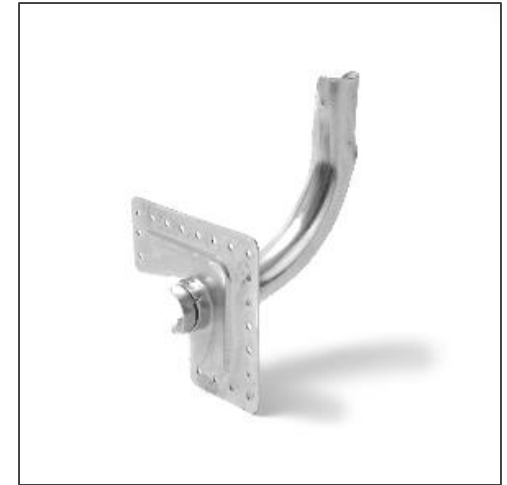
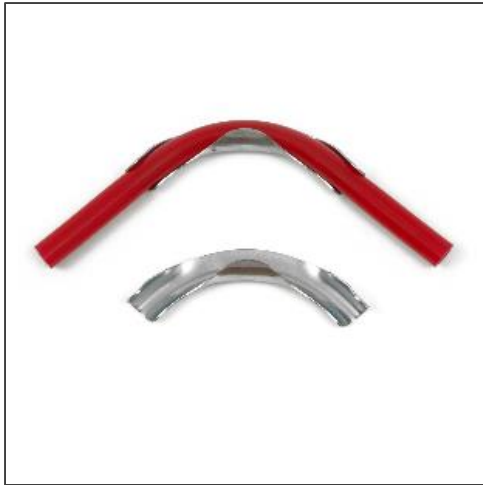

Installation Techniques

Bending and Flexibility

- Some installers prefer to install elbows
- Elbows may be necessary in confined areas



Installation Techniques

Fastening PEX

- Horizontal runs should be supported every **32 inches (80 cm)** for sizes $\leq 1''$ and every **48 inches (120 cm)** on diameters $> 1''$
- Vertical runs must be supported every **60 inches**
- Steel support channel can extend hanger spacing to **8 ft (2.4 m)**
 - Support channel is often used in commercial installations

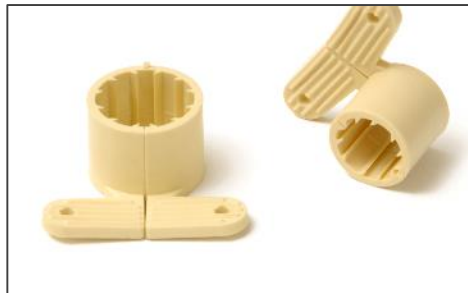

Installation Techniques

Fastening PEX: Commercial Applications with Support Channel

- Galvanized steel support channel reduces hanger spacing and thermal expansion
- Channel is typically used with clevis hangers @ 6 to 8 ft. (1.8 - 2.4 m) hanger spacing



Installation Techniques

Fastening PEX: Commercial Applications with Support Channel

- Galvanized steel support channel reduces hanger spacing and thermal expansion
- Channel is typically used with clevis hangers @ 6 to 8 ft. (1.8 - 2.4 m) hanger spacing



Installation Techniques

Protection

- Protect PEX from abrasion and obvious abuse like cuts or gouges
- Use sleeves or plastic isolators through metal studs (not required in wood studs) to avoid continuous abrasion

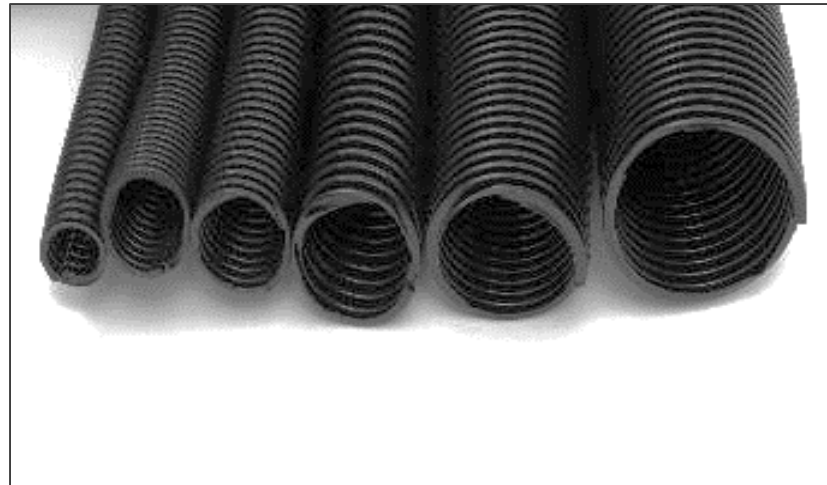

Installation Techniques

Protection

- Use hangers that are smooth without sharp edges - plastic is preferred
 - Hangers should not pinch the tube
- Use nail plates where PEX passes within 2 in. (5 cm) of a nailing surface on a stud

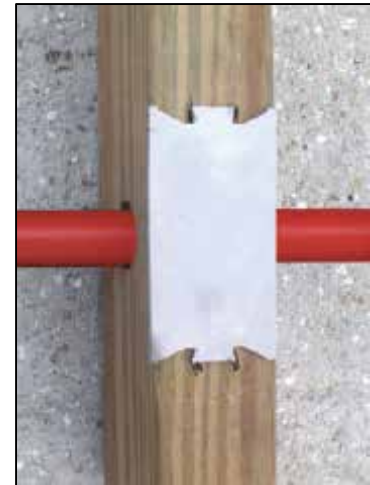

Installation Techniques

Fire Stopping

- When plastic pipe penetrates a fire-rated assembly (i.e., floor, ceiling, wall), the penetration must be protected by an approved through-penetration **firestop system**
- Solutions include intumescent caulks, wrap strips, pass-through devices, collars and cast-in-place sleeves
- Many firestop manufacturers have products listed for use with PEX tubing

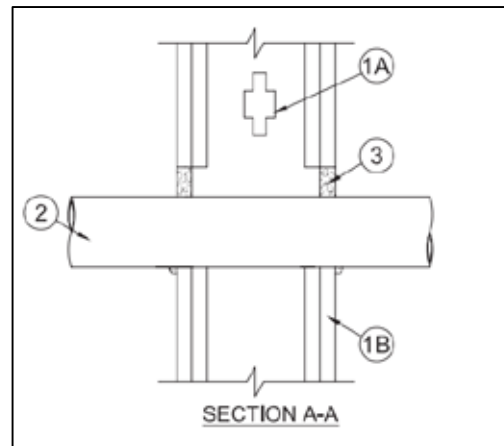

Installation Techniques

Installation Under Slabs

- PEX plumbing is recommended for use under slabs in most applications
- Installers must protect PEX from abrasion
 - Sleeve tubing where it passes through concrete to protect against abrasion
- It's recommended to insulate hot-water PEX tubing within slabs

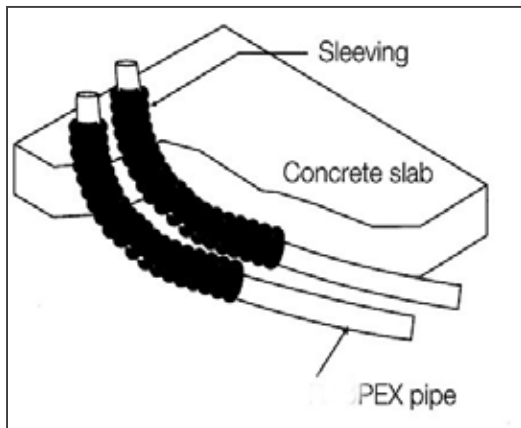

Installation Techniques

Longitudinal Expansion and Contraction

- Linear expansion rate of PEX: **1.1 inch per 10°F per 100 ft. length**
- Expansion is usually accommodated by the tubing's flexibility ≤ 1 inch sizes
 - Allow **1/8 inch slack per foot** of installed tubing
- Offsets and loops can accommodate high expected expansion and contraction

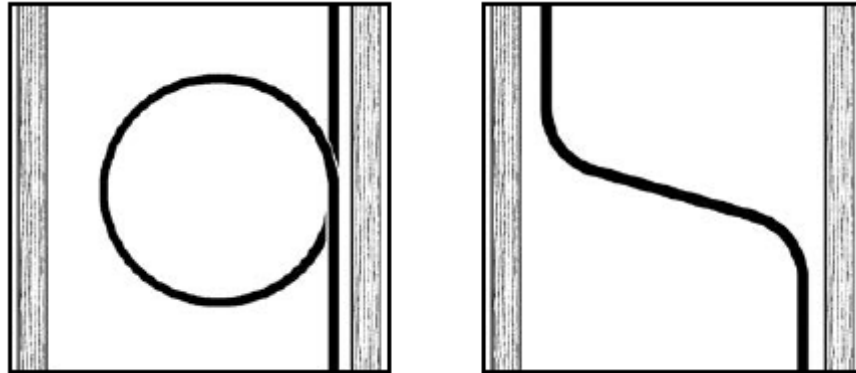

Installation Techniques

Longitudinal Expansion and Contraction

- Expansion loops/arms/legs may be needed, depending on installation type, the expected temperature changes and tubing size
- www.plasticpipecalculator.com helps with these calculations

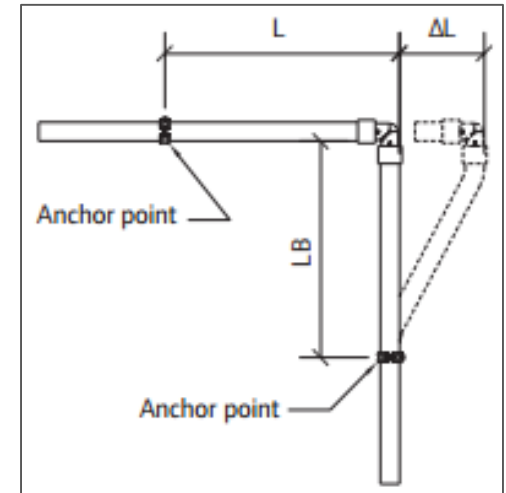

Installation Techniques

Pressure Testing

- Pressure test as required by manufacturer or local code
- **Minimum recommended test pressure 40 psi; Maximum up to 200 psig**
- Water tests are acceptable – do not allow water to freeze

Installation Techniques

Pressure Testing - Air

- PEX is a ductile material, does not separate when burst, even at cold temperatures
- See PPI **Recommendation F *Testing PEX Pipe and Tubing Systems with Air***
- “It is the recommendation of PPI that PEX piping systems be permitted to be tested with compressed air or inert gas, provided that the manufacturer’s instructions are followed and that all testing is performed in accordance with the local regulations.”
- **WARNING:** *Compressed air or inert gas (e.g. nitrogen) used for pressure testing has high potential (stored) energy. Any uncontrolled release of that energy can lead to a sudden rupture which may present serious safety hazards.*

Installation Techniques

Summary: This Learning Objective discussed installation techniques

1. Bending and flexibility
2. Fasteners
3. Protection
4. Installation under slabs
5. Linear expansion and contraction
6. Pressure testing



5. Industry Resources

PPI's BCD webpages provide access to:

- Technical Publications
- Plastic Pressure Pipe Design Calculator
- Presentations and recorded webinars
- Educational videos
- Case studies
- Industry Links
- www.plasticpipe.org

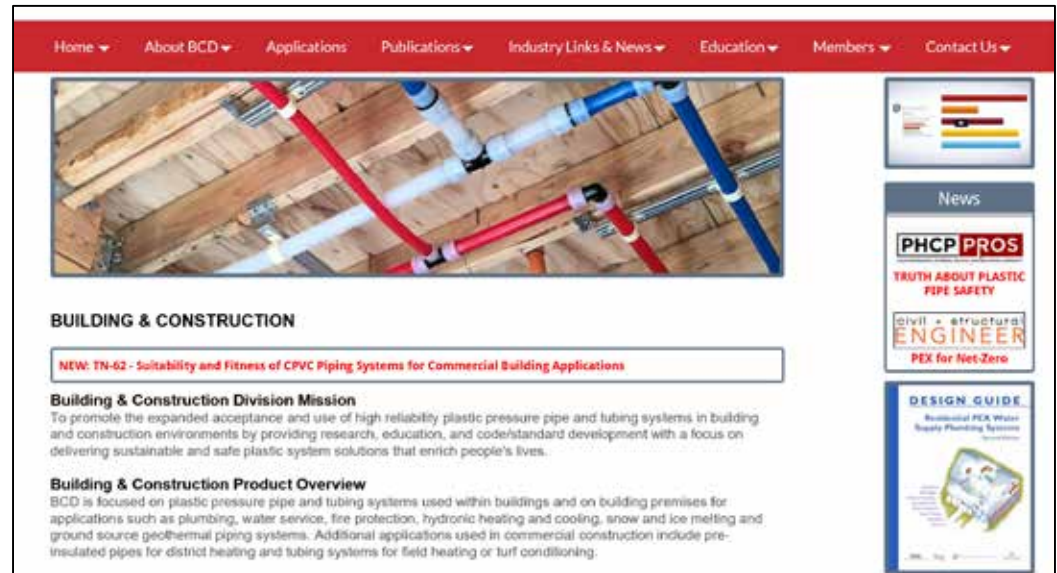

Home ▾ About BCD ▾ Applications ▾ Publications ▾ Industry Links & News ▾ Education ▾ Members ▾ Contact Us ▾



BUILDING & CONSTRUCTION

NEW: TN-02 - Suitability and Fitness of CPVC Piping Systems for Commercial Building Applications

Building & Construction Division Mission

To promote the expanded acceptance and use of high reliability plastic pressure pipe and tubing systems in building and construction environments by providing research, education, and code/standard development with a focus on delivering sustainable and safe plastic system solutions that enrich people's lives.

Building & Construction Product Overview

BCD is focused on plastic pressure pipe and tubing systems used within buildings and on building premises for applications such as plumbing, water service, fire protection, hydronic heating and cooling, snow and ice melting and ground source geothermal piping systems. Additional applications used in commercial construction include pre-insulated pipes for district heating and tubing systems for field heating or turf conditioning.

News

PHCP PROS
TRUTH ABOUT PLASTIC PIPE SAFETY

civil + structural
ENGINEER
PEX for Net-Zero

DESIGN GUIDE
Residential PEX Water Supply Plumbing Systems

Industry Resources

PPI's BCD webpages provide access to:

- Technical Publications
- Plastic Pressure Pipe Design Calculator
- Presentations and recorded webinars
- Educational videos
- Case studies
- Industry Links
- www.plasticpipe.org

BUILDING & CONSTRUCTION RELATED LITERATURE

Statements

- PPI Technical Response to "Metal Accumulation in Representative Plastic Drinking Water Plumbing Systems"
- Statement A - Relative Oxidative Aggressiveness of Chloramines and Free Chlorine Disinfectants on Crosslinked Polyethylene (PEX) Pipes Used in Treated Potable Water
- Statement Y - Taste and Odor of Drinking Water from Plastic Piping Systems

Recommendations

- Recommendation E - Recommendation Against Mixing Hydronic Heating Water with Potable Water
- Recommendation F - Testing PEX Pipe and Tubing Systems with Air
- Recommendation G - Epoxy Pipe Coatings

Position Papers

- Installation of CPVC Fittings Within and Under Concrete Slabs
- Installation of PEX Fittings Within and Under Concrete Slabs

Technical Notes

- TN-17 - Crosslinked Polyethylene (PEX) Pipe & Tubing
- TN-26 - Erosion Study on Brass Insert Fittings used in PEX Piping Systems
- TN-31 - Differences Between PEX and PB Piping Systems for Potable Water Applications
- TN-32 - UV Labeling Guidelines for PEX Pipes
- TN-39 - Recommended Practices Regarding Application of Pesticides and Termiticides near PEX Pipes
- TN-52 - Guide to High-Temperature Applications of Non-Potable PEX Pipe and Tubing Systems
- TN-53 - Guide to Chlorine Resistance Ratings of PEX Pipes and Tubing for Potable Water Applications
- TN-55 - Plastic Piping Materials for Geo Applications
- TN-56 - Plastic Piping Materials Near Recessed Lighting Fixtures
- TN-57 - Proper Integration of Copper Tubing and Components with PP-R Piping Materials for Plumbing Applications
- TN-62 - Suitability and Fitness of CPVC Piping Systems for Commercial Building Applications

Technical Reports

- PPI Technical Response to AWWA Journal Paper 11-17
- TR-11 - Resistance of Thermoplastic Piping Materials to Micro- and Macro-Biological Attack
- TR-48 - R-Value and Thermal Conductivity of PEX and PE-RT
- Fixture Flow Rate Comparison Cross-Linked Polyethylene (PEX) Piping and Copper Tubing
- NAHB-RC Surge Pressure in Plumbing Pipe Materials
- Jana Report 05-1059 - Proposal for the Evaluation of the Chlorine Resistance of UV Exposed PEX Pipe
- Jana Report 09-1190 - Usage and Effects of Chlorine Dioxide on PEX Plumbing
- Jana Report (2003) - Oxidative Resistance of Sulfone Polymers to Chlorinated Potable Water
- Jana Report - Chlorine Resistance Testing of PEX Piping Materials

Industry Resources

PPI Technical Notes and Reports

Example: TN-53: *Guide to Chlorine Resistance Ratings of PEX Pipes and Tubing for Potable Water Applications*

Excerpt:

“Thanks to the many benefits of PEX tubing materials and the associated fittings and system components, it has become common for engineers, builders and plumbers to employ PEX potable water systems for drinking water applications.

“However, for operating conditions beyond the typical “domestic hot” temperature of 140°F (60°C) or system pressure of 80 psig (0.55 MPa), users should contact the specific PEX tubing manufacturer to determine whether such conditions are approved for use.”

Industry Resources

PPI Statements

Example: Statement A: *Relative Oxidative Aggressiveness of Chloramines and Free Chlorine Disinfectants used in Treated Potable Water on Crosslinked Polyethylene (PEX) Pipe*

Excerpt:

“Based on these results, it is the position of PPI BCD that chloramines are less aggressive than free chlorine to PEX pipes. Testing of oxidative resistance using free chlorine, in accordance with ASTM F2023, will provide a conservative estimate of the time-to-failure for PEX pipes when used with the disinfectant chloramines.”

Industry Resources

PPI Recommendations

Example: **Recommendation E: *Recommendation Against Mixing Hydronic Heating Water with Potable Water***

Excerpt:

“Therefore, it is the recommendation of the PPI that designers and installers not specify or build systems where the mixing of hydronic water with potable water may occur.”

Industry Resources

PPI Recommendations

Example: **Recommendation F: *Testing PEX Pipe and Tubing Systems with Air***

Excerpt:

“It is the recommendation of the PPI that PEX pipe and tubing systems be permitted to be tested with compressed air or inert gas, provided that the manufacturer’s instructions are followed and that all testing is performed in accordance with the local code regulations.”

Industry Resources

PPI Recommendations

Example: Recommendation G: *Recommendation Against Using Epoxy Pipe Coatings Within Plumbing Systems Including Plastic Components*

Excerpt:

“Therefore, it is the recommendation of the Plastics Pipe Institute that epoxy repair coatings not be applied to plumbing distribution systems which contain plastic pressure pipes, tubing, fittings or valves of materials such as CPVC, PE-RT, PEX, or PP-R/PP-RCT. All plastic components should be isolated from metal piping before the installation of such coatings.”

Industry Resources

Educational Videos

- Short videos explaining how to work with PEX tubing and fittings
- *PEX Sizes and Colors*
- *Using Manifolds*
- *Support Bends*

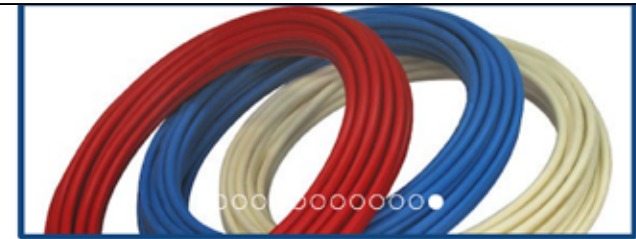

BUILDING & CONSTRUCTION VIDEOS

ABOUT THIS VIDEO LIBRARY:

PPI has developed this video channel as a service to the industry. The information presented here is offered in good faith and believed to be accurate, but is offered without any warranty, expressed or implied including **WARRANTIES OF MERCHANTABILITY AND FITNESS FOR A PARTICULAR PURPOSE**. Any reference to particular proprietary product should not be construed as an endorsement by PPI, which does not endorse the proprietary products or processes of any manufacturer. PPI assumes no responsibility for viewer's compliance with applicable laws and regulations.

 Click on image to view full screen



PPI's BCD Division

A brief overview and introduction to the Building and Construction Division (BCD), one of the Divisions of the Plastics Pipe Institute (PPI).



PEX Systems Using Manifolds

Both time and materials may be saved when plumbing with the use of manifolds, now available in copper or plastic.

Industry Resources

Educational Presentations

- *Design and Installation of Hydronic Snow and Ice Melting Systems...*
- *Achieving Net-Zero with Plastic Piping Solutions*
- *PEX for NFPA 13D Residential Fire Sprinkler...*
- *PEX for Water Service Line Applications*

PRESENTATIONS
 Click on images below to view PDF presentations.

 <p>Ultraviolet (UV) Resistance of PEX Tubing</p> <p>A presentation by the Plastics Pipe Institute</p> <p>CASPE CEU PROVIDER</p> <p>Speaker: Lorne Hoffman, P.Eng. (l.hoffman@ppipipe.com) PEI Director of Engineering, Building & Construction Division (416) 291-1000</p>	 <p>Designing PEX Plumbing Systems to Optimize Performance and Efficiency</p> <p>A presentation by the Plastics Pipe Institute</p> <p>CASPE CEU PROVIDER</p> <p>Speaker: Lorne Hoffman, P.Eng. (l.hoffman@ppipipe.com) PEI Director of Engineering, Building & Construction Division (416) 291-1000</p>	 <p>Design and Installation of Hydronic Snow and Ice Melting Systems to Optimize Performance and Efficiency</p> <p>A presentation by the Plastics Pipe Institute</p> <p>CASPE CEU PROVIDER</p> <p>Speaker: Lorne Hoffman, P.Eng. (l.hoffman@ppipipe.com) PEI Director of Engineering, Building & Construction Division (416) 291-1000</p>
 <p>Today's Plastic Piping Solutions for Building and Construction</p> <p>A presentation by the Plastics Pipe Institute</p> <p>Speaker: Lorne Hoffman, P.Eng. (l.hoffman@ppipipe.com) PEI Director of Engineering, Building & Construction Division (416) 291-1000</p>	 <p>Achieving Zero Energy Ready with Plastic Piping Solutions</p> <p>A presentation by the Plastics Pipe Institute for DOE Race To Zero Design Teams</p> <p>ZERO ENERGY</p>	 <p>Plastic Piping Materials for Geothermal & Greenhouse Ground Loops</p>

Industry Resources

Industry Links Webpage

- Direct access to standards development organizations (SDOs), product certification agencies, code bodies, and other associations through this BCD webpage

<http://plasticpipe.org/building-construction/bcd-links.html>

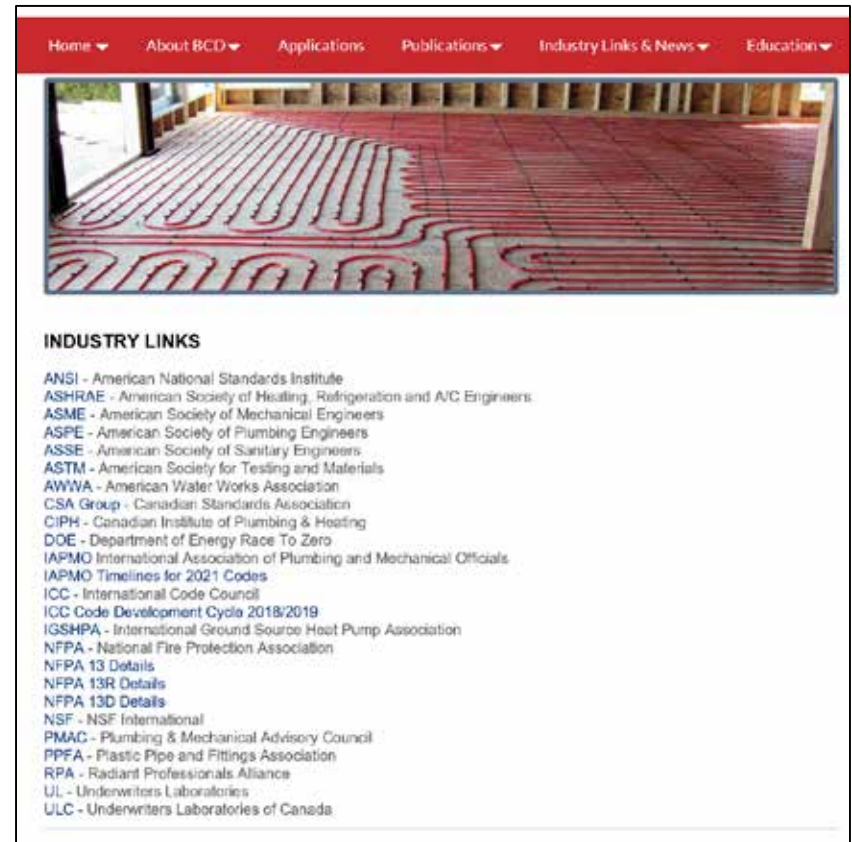

The screenshot shows the 'Industry Links' webpage. At the top is a red navigation bar with the following menu items: Home, About BCD, Applications, Publications, Industry Links & News, and Education. Below the navigation bar is a large photograph of a room with red radiant floor heating pipes installed in a grid pattern. Underneath the photo is the heading 'INDUSTRY LINKS' followed by a list of industry organizations and their full names.

INDUSTRY LINKS

- ANSI - American National Standards Institute
- ASHRAE - American Society of Heating, Refrigeration and A/C Engineers
- ASME - American Society of Mechanical Engineers
- ASPE - American Society of Plumbing Engineers
- ASSE - American Society of Sanitary Engineers
- ASTM - American Society for Testing and Materials
- AWWA - American Water Works Association
- CSA Group - Canadian Standards Association
- CIPH - Canadian Institute of Plumbing & Heating
- DOE - Department of Energy Race To Zero
- IAPMO International Association of Plumbing and Mechanical Officials
- IAPMO Timelines for 2021 Codes
- ICC - International Code Council
- ICC Code Development Cycle 2018/2019
- IGSHPA - International Ground Source Heat Pump Association
- NFPA - National Fire Protection Association
- NFPA 13 Details
- NFPA 13R Details
- NFPA 13D Details
- NSF - NSF International
- PMAC - Plumbing & Mechanical Advisory Council
- PPFA - Plastic Pipe and Fittings Association
- RPA - Radiant Professionals Alliance
- UL - Underwriters Laboratories
- ULC - Underwriters Laboratories of Canada

Course Review

By this time, participants should be able to:

1. Explain how the properties of PEX tubing and fittings can improve health, safety and welfare through improved plumbing materials
2. Describe three distinct plumbing layouts using PEX systems and compare advantages and disadvantages of each
3. Apply test data from published research to demonstrate how design of the plumbing layout can improve system performance and provide faster delivery of hot-water with reduced water waste
4. Direct an installer on correct installation techniques for PEX systems to ensure long-term safety and performance
5. Discuss how to access industry resources for material, design and installation info

Conclusion

By applying proper design techniques, PEX plumbing systems can deliver the optimum combination of performance, efficiency, cost and longevity

Much additional information about design and installation of PEX plumbing systems is found within the DESIGN GUIDE, so please refer to this document for details not covered in today's presentation at www.plasticpipe.org

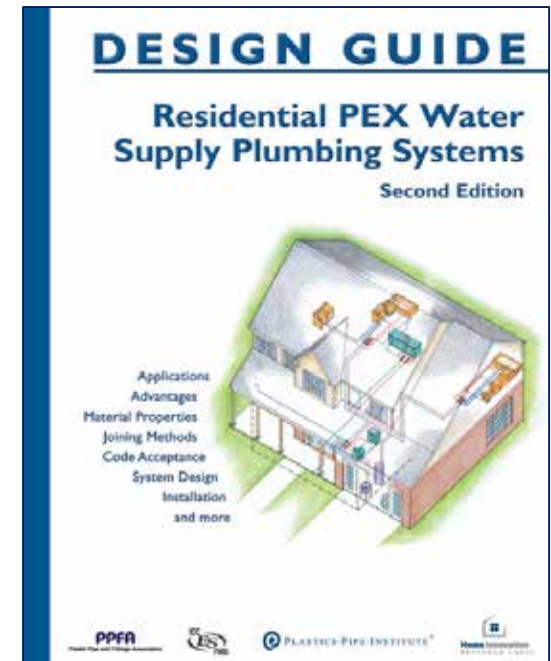

Designing PEX Plumbing Systems to Optimize Performance and Efficiency

Thank you!

Contact

Lance MacNevin, P.Eng.

PPI Director of Engineering - Building & Construction Division

Imacnevin@plasticpipe.org Tel (469) 499-1057